



HYDRAULIC PULLER SET

MODEL NO: **PS982.V2**

Thank you for purchasing a Sealey product. Manufactured to a high standard, this product will, if used according to these instructions, and properly maintained, give you years of trouble free performance.

IMPORTANT: PLEASE READ THESE INSTRUCTIONS CAREFULLY. NOTE THE SAFE OPERATIONAL REQUIREMENTS, WARNINGS & CAUTIONS. USE THE PRODUCT CORRECTLY AND WITH CARE FOR THE PURPOSE FOR WHICH IT IS INTENDED. FAILURE TO DO SO MAY CAUSE DAMAGE AND/OR PERSONAL INJURY AND WILL INVALIDATE THE WARRANTY. KEEP THESE INSTRUCTIONS SAFE FOR FUTURE USE.



Refer to Instructions



Wear Eye Protection

1. SAFETY

- ❑ **WARNING!** Ensure all Health and Safety, local authority, and general workshop practice regulations are strictly adhered to when using tools.
 - ✗ **DO NOT** use tools if damaged or worn.
 - ✓ Maintain the tools in good and clean condition for best and safest performance.
 - ✓ Ensure all threads are clean and well lubricated.
 - ✓ Always check that puller is correctly assembled and is square with the workpiece.
 - ✓ If vehicle is raised, ensure it is adequately supported with axle stands, ramps, etc. as appropriate.
 - ✓ Wear suitable clothing to avoid snagging. Do not wear jewellery. Tie back long hair.
 - ✓ Wear approved eye protection. A full range of personal safety equipment is available from your Sealey dealer.
 - ✓ Where possible shield workpiece with canvas or similar to provide protection against failed parts.
 - ✗ **DO NOT** heat puller jaws when heating a gear or bearing as this will affect the temper and, therefore, the strength of the material.
 - ✗ **DO NOT** use any tool or lever to turn the ram tommy bar, use hand effort only.
 - ✗ **DO NOT** hit workpiece, or ram, with a hammer if workpiece has not moved with maximum puller force applied. Use a larger capacity puller.
 - ✓ Account for all tools and parts being used and do not leave them in or on the vehicle.
- IMPORTANT:** Always refer to the vehicle manufacturer's service instructions, or proprietary manual, to establish the correct procedure and data. These instructions for use are provided as a guide only.

2. INTRODUCTION

PS982 consists of a set of gear pullers and a forged steel bearing separator, all operated by a 10 tonne hydraulic ram. The ram is also compatible with sets PS981 and PS983.

3. CONTENTS

Item	Part No.	Description
1	PS982/8004	Leg, 100mm x 3
2	PS982/8006	Leg, 150mm x 3
3	PS982/8008	Leg, 200mm x 3
4	PS982/9016	Rod, Main x 2
5	PS982/9017	Rod, Extension x 2
6	PS982/8011	Ring, Ram Adaptor
7	PS982/8014	Rod, Ram Extension, 50mm
8	PS982/8015	Rod, Ram Extension, 100mm
9	PS982/8013	Centre Adaptor, 1¼"
10	PS990	Ram, Hydraulic, 10 tonne
11	PS982/9013	Head, Triple
12	PS982/8012	Head, Twin
13	PS982.V2-B	Bearing Separator, 75-105mm
14	PS982/9014	Beam
	PS982/OIL	15gm of oil for a single refill (not supplied)
	PS982/8002	Repair Kit for PS990 Ram (not supplied)

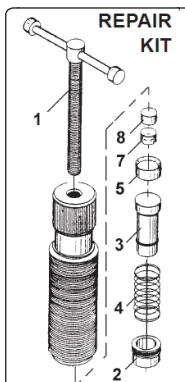
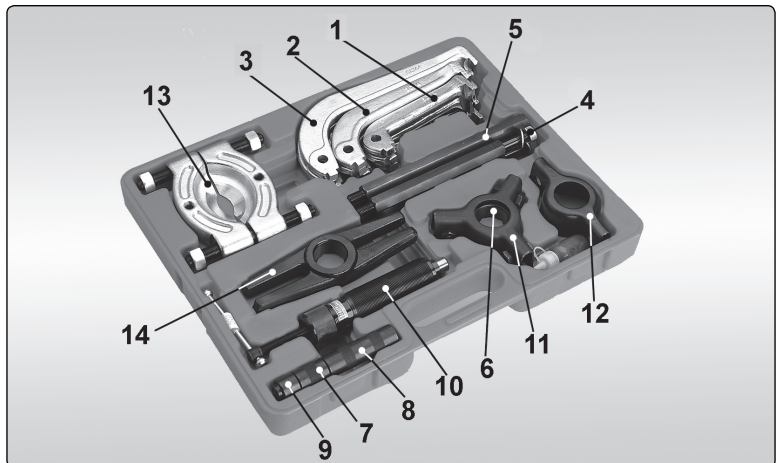

4. OPERATION

- ❑ **WARNING! Ensure that you read, understand and apply the safety instructions in Section 1.**
- 4.1. Confirm that the workpiece is retained by interference fit (parallel or taper) only.
- 4.2. Assemble the appropriate puller, see (fig.1) and adjust T-handle (fig. 2.A) so that tommy bar (fig.2.B) is approximately 80mm (3") above top of ram, see (fig.2).
- 4.3. Fit the puller claws behind the workpiece and then screw ram **body** down, with centre adaptor (item 9) over piston end, until centre adaptor point locates in end of shaft from which workpiece is to be pulled. If necessary use ram extension(s) (items 7 & 8) to achieve this.
- 4.4. Turn T-handle clockwise, by hand only, to pull workpiece from shaft, draw workpiece up shaft. Do not screw T-handle in further than 25mm (1") from end of the ram (see fig.2). If workpiece requires additional movement then unscrew T-handle to 80mm from end of ram, screw ram body down so that centre adaptor again contacts shaft and then continue to draw workpiece up shaft.
- 4.5. **IMPORTANT:** The maximum safe load for the puller can be achieved by hand effort alone.
- 4.6. **The use of tools or levers on the tommy bar to increase the load will damage the puller and may result in injury.** Such misuse will also invalidate the warranty. If the workpiece does not move, with maximum puller force applied, **DO NOT** hit it, or the puller, in an attempt to free it. Damage to puller/workpiece and personal injury may result: use a larger capacity puller.

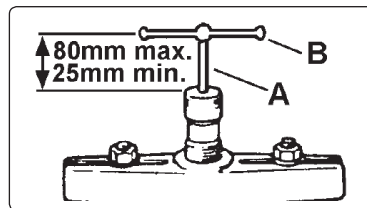
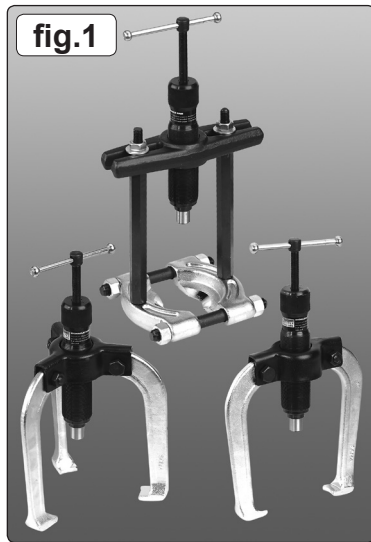

fig.2

5. MAINTENANCE

5.1. GENERAL

- 5.1.1. Keep all items clean and lightly oiled. Keep all threads free from grit and lubricate the ram regularly.
- 5.1.2. Store the ram in the closed position to prevent piston surface corrosion.

5.2. TO CHANGE OIL IN RAM

IMPORTANT: The hydraulic system operates on a specially formulated oil which must be replaced from time to time. Use **Sealey Hydraulic Jack Oil**, available from your authorised Sealey dealer. Quote model number: **HJO500MLS** for 1 x 500ml bottle or **PS982/OIL** for 15gm of oil for a single refill.

- ❑ **WARNING!** Use of any other oil in ram may cause ram to fail and will invalidate your warranty. Wear appropriate eye, face and hand protection.
- 5.2.1. Dismantle by removing the ram cover (fig.3.2) with soft jaw grips (fig.3.A) (body may have to be held in a soft jaw vice, ensure bodythread is not damaged).
- ▲ **CAUTION!** The cover is spring loaded, take care when removing. Remove components 2, 3, and 4 from the cylinder carefully.
- 5.2.2. Screw T-handle (fig.4.5) down as far as it will go, then unscrew and remove it from the body (fig.4.5).
- 5.2.3. Push a narrow screw driver (fig.4.9), or a rod of appropriate diameter, down the small opening in head of ram (fig.4.B), in order to push components (fig.4.6, 7, and 8) plus the oil, out of the main cylinder.
NOTE: A medium force may be required.
- 5.2.4. Remove remaining oil from main cylinder, clean all components and replace any showing signs of damage or wear.
- 5.2.5. Take small seal and piston (fig.5.7 & 8) and gently push them down the narrow bore of the cylinder ensuring the metal piston (fig.5.8) is first, with the concave face pointing in the direction of the T-handle, and the seal (fig.5.7) second, with the widest part of the seal facing upwards towards the main cylinder (fig.5.7). Push into bore as far as possible.

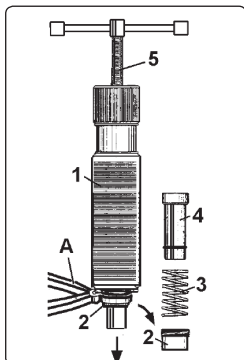

fig.3

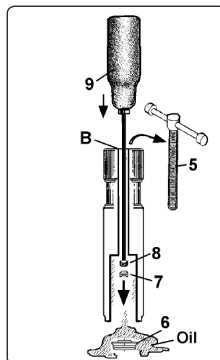

fig.4

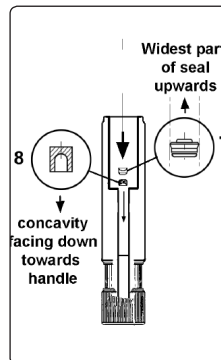

fig.5

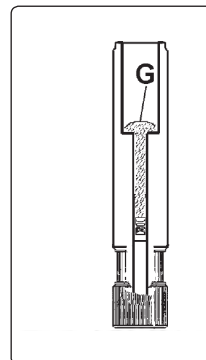

fig.6

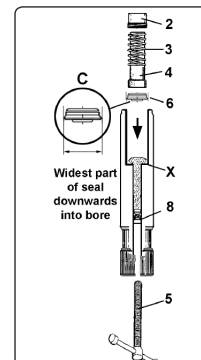

fig.7

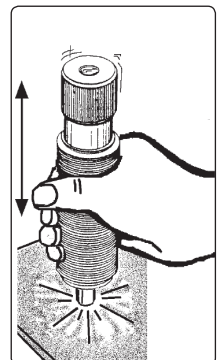

fig.8

- 5.2.6. Pour 15gm of oil into the bore (fig.6). Insert larger seal (fig.7.6) as shown, with the widest part of the seal facing downwards into the bore. Push down into main cylinder as far as 'X' (fig.7) followed by piston (fig.7.4) and spring (fig.7.3).
- 5.2.7. Refit (do not overtighten) ram cover (fig.7.2) and replace T-handle (fig.7.5).
- **WARNING!** The correct orientation of pistons and seals in the ram is critical.
- 5.2.8. Screw T-handle into ram until it contacts small piston and then turn a further two or three times.
- 5.2.9. Remove T-handle and firmly bounce the ram piston (fig.8) on a hard, but non-damaging, surface 6 to 10 times to consolidate the oil.
- 5.2.10. Replace the T-handle, wipe clean and the ram is ready for use.
- 5.3. MAINTENANCE OF EARLY MODELS**
- NOTE:** Earlier models of the PS990 were filled with a hydraulic grease.
- **WARNING! DO NOT** put oil into units previously filled with grease as the seals will be configured for grease only and will leak if used with oil.
- 5.4. CONVERTING EARLY MODELS TO OIL**
- 5.4.1. The old type grease filled PS990 can be converted for use with oil by replacing the internal components with those supplied in the repair kit Part No PS982/8002. **DO NOT** mix old and new components. A single 15gm refill of oil may be obtained by quoting Part no. PS982/OIL.



ENVIRONMENT PROTECTION

Recycle unwanted materials instead of disposing of them as waste. All tools, accessories and packaging should be sorted, taken to a recycling centre and disposed of in a manner which is compatible with the environment. When the product becomes completely unserviceable and requires disposal, drain any fluids (if applicable) into approved containers and dispose of the product and fluids according to local regulations.

Note: It is our policy to continually improve products and as such we reserve the right to alter data, specifications and component parts without prior notice.

Important: No Liability is accepted for incorrect use of this product.

Warranty: Guarantee is 12 months from purchase date, proof of which is required for any claim.

Sealey Group, Kempson Way, Suffolk Business Park, Bury St Edmunds, Suffolk. IP32 7AR



01284 757500



01284 703534



sales@sealey.co.uk



www.sealey.co.uk