



1L PNEUMATIC VACUUM SINGLE & TWIN BRAKE CALIPER/CLUTCH BLEEDER

MODEL NO: **VS020TC**

Thank you for purchasing a Sealey product. Manufactured to a high standard, this product will, if used according to these instructions, and properly maintained, give you years of trouble free performance.

IMPORTANT: PLEASE READ THESE INSTRUCTIONS CAREFULLY. NOTE THE SAFE OPERATIONAL REQUIREMENTS, WARNINGS & CAUTIONS. USE THE PRODUCT CORRECTLY AND WITH CARE FOR THE PURPOSE FOR WHICH IT IS INTENDED. FAILURE TO DO SO MAY CAUSE DAMAGE AND/OR PERSONAL INJURY AND WILL INVALIDATE THE WARRANTY. KEEP THESE INSTRUCTIONS SAFE FOR FUTURE USE.



Refer to instructions



Wear eye protection



Wear protective gloves

1. SAFETY

IMPORTANT Operating guidelines are provided with every brake bleeder. However, for definitive information relating to the correct method of bleeding a particular vehicle's system, always refer to the vehicle manufacturer's instructions.

- ✓ Familiarise yourself with the applications and limitations, as well as any potential hazards, of the kit.
- ✓ Keep this product in good working order and condition. (Take immediate action to repair or replace damaged parts).
- ✓ Use approved parts only (unapproved parts may be dangerous and will invalidate the warranty).
- ✓ Keep children and unauthorised persons away from the work area.
- ✓ Keep work area clean and tidy and free from unrelated materials.
- ✓ Ensure the work area has adequate lighting.
- ✗ **DO NOT** use the kit to perform a task for which it is not designed.
- ✗ **DO NOT** allow untrained persons to use the kit.
- ✗ **DO NOT** use whilst under the influence of drugs, alcohol or intoxicating medication.
- ✓ After use, clean equipment and store in a cool, dry, childproof area.
- ✓ Dispose of waste liquids in accordance with local authority regulations.
- ✓ Always read and comply with the warnings on the brake fluid container.
- ✓ Wear eye protection and keep skin contact to a minimum. If brake fluid enters eyes, rinse with plenty of water and seek medical advice. If swallowed seek medical advice immediately.
- ☐ **WARNING!** Brake fluid is flammable - keep away from sources of ignition, including hot surfaces e.g. exhaust manifold.
- ☐ **WARNING!** Brake fluid will damage paintwork. Any spillage should be flushed with water immediately.
- ✓ After use, clean equipment and store in a cool, dry, childproof area.

2. INTRODUCTION

Simple, 1-person operation using standard workshop air supply (90-120psi). Quick, clean and efficient. Does not require specialised brake reservoir caps. Supplied with two bleed lines for twin caliper systems. Draws fluid from the bleed nipple enabling either bleeding or full replacement of fluid in system.

3. SPECIFICATION

MODEL NO:..... **VS020TC**
 Air Consumption: 180L/min
 Inlet Size: 1/4" BSP
 Maximum Air Supply: 120psi
 Tank Capacity: 1L

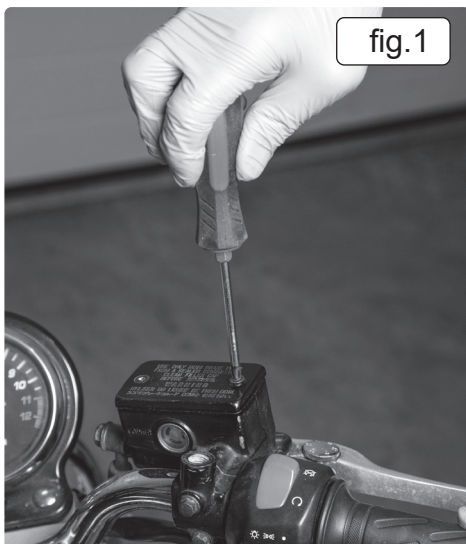

fig.1

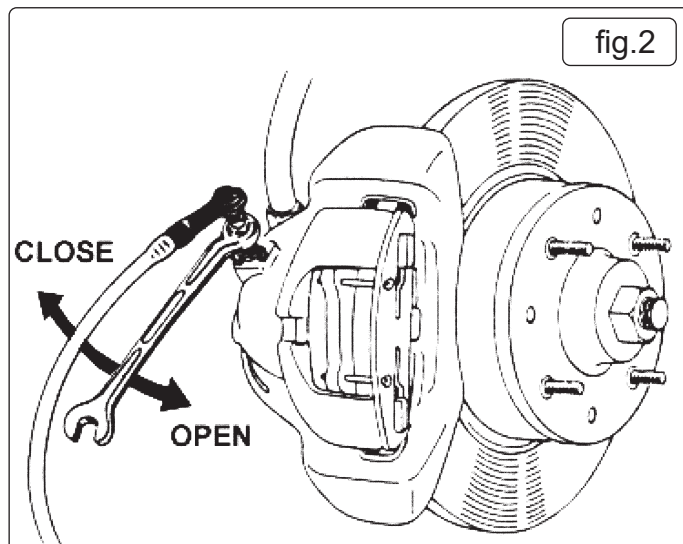

fig.2

4. OPERATION

4.1. BRAKE BLEEDING PROCEDURE.

- × **DO NOT** touch the vehicle's brake lever or pedal whilst bleeding the brakes.
 - ✓ Refer to the vehicle manufacturer's instructions for brake bleeding and wheel sequence before proceeding.
 - **WARNING!** Familiarise yourself with the hazards of brake fluid - read manufacturer's instructions on the container.
- 4.1.1. Remove the lid of the vehicle's brake fluid reservoir. (See fig.1)
 - 4.1.2. Connect the brake bleeder to a suitable compressed air unit.
 - 4.1.3. Mount the rubber pipes onto the brake nipples on the front wheel and open the nipples about 1/4 of a turn. (See fig.2)
 - 4.1.4. Activate the brake bleeder's trigger. The vacuum created will draw the brake fluid from the vehicle's brake system.
 - 4.1.5. Check the level of the brake fluid in the reservoir and top up if necessary.
 - 4.1.6. Continue to bleed the system and top up the reservoir until there are no air bubbles visible in the clear tube.
 - 4.1.7. Close the brake nipples. (See fig.2)
 - 4.1.8. Remove the rubber pipes from the brake nipples.
 - 4.1.9. Depress the trigger to remove brake fluid from the clear pipe.
 - 4.1.10. Repeat the process at each wheel in turn.

4.2. CHANGING THE BRAKE FLUID

- 4.2.1. Repeat the brake bleeding procedure as described above until the master cylinder reservoir is at its minimum level. Fill the reservoir with new brake fluid and continue to bleed the system. Check reservoir level regularly.
- 4.2.2. When new fluid can be seen in the clear tube tighten the brake nipples.
- 4.2.3. Repeat this procedure at every wheel.
 - **WARNING:** When brake bleeding and/or fluid changing is complete, test action of front hand lever and rear brake pedal to ensure that the brakes are working before driving the vehicle.
- 4.2.4. Apply copper grease to the brake bleed nipples before and after the brake bleeding procedure to eliminate the possibility of seized or broken nipples when the brakes are next bled.



ENVIRONMENT PROTECTION

Recycle unwanted materials instead of disposing of them as waste. All tools, accessories and packaging should be sorted, taken to a recycling centre and disposed of in a manner which is compatible with the environment. When the product becomes completely unserviceable and requires disposal, drain any fluids (if applicable) into approved containers and dispose of the product and fluids according to local regulations.

Note: It is our policy to continually improve products and as such we reserve the right to alter data, specifications and component parts without prior notice.

Important: No Liability is accepted for incorrect use of this product.

Warranty: Guarantee is 12 months from purchase date, proof of which is required for any claim.

Sealey Group, Kempson Way, Suffolk Business Park, Bury St Edmunds, Suffolk. IP32 7AR



01284 757500



01284 703534



sales@sealey.co.uk



www.sealey.co.uk