

# SEALEY

## 6/12/24V DIGITAL START/STOP BATTERY & ALTERNATOR TESTER WITH PRINTER

MODEL NO: **BT2014**

Thank you for purchasing a Sealey product. Manufactured to a high standard, this product will, if used according to these instructions, and properly maintained, give you years of trouble free performance.

**IMPORTANT:** PLEASE READ THESE INSTRUCTIONS CAREFULLY. NOTE THE SAFE OPERATIONAL REQUIREMENTS, WARNINGS & CAUTIONS. USE THE PRODUCT CORRECTLY AND WITH CARE FOR THE PURPOSE FOR WHICH IT IS INTENDED. FAILURE TO DO SO MAY CAUSE DAMAGE AND/OR PERSONAL INJURY AND WILL INVALIDATE THE WARRANTY. KEEP THESE INSTRUCTIONS SAFE FOR FUTURE USE.



Refer to instructions



Wear eye protection



Wear protective clothing



Wear protective gloves



Warning: explosive material



Warning: corrosive substance

### 1. SAFETY

- ▲ **DANGER! BE AWARE, LEAD-ACID BATTERIES GENERATE EXPLOSIVE GASES DURING NORMAL BATTERY OPERATION. FOR THIS REASON, IT IS VERY IMPORTANT TO READ AND FOLLOW THESE INSTRUCTIONS CAREFULLY, EACH TIME YOU USE THE BATTERY TESTER.**

Follow these instructions and those published by the battery and vehicle manufacturers, and the maker of any equipment you intend to use in the vicinity of the battery. Remember to review warning marks on all products and on engines.

#### 1.1. PERSONAL PRECAUTIONS

- ✓ Ensure that there is another person within hearing range and close enough to come to your aid, should a problem arise when working near a lead-acid battery.
- ✓ Wear safety eye protection and protective clothing. Avoid touching eyes while working near battery.
- ✓ Have fresh water and soap nearby in case battery acid contacts skin, clothing, or eyes.
- ✓ Wash immediately with soap and water if battery acid contacts skin or clothing. If acid enters eye, flush eye immediately with cool, clean running water for at least 15 minutes and seek immediate medical attention.
- ✓ Remove personal metallic items such as rings, bracelets, necklaces and watches. A lead-acid battery can produce a short-circuit current which is high enough to weld such items to the vehicle and cause severe burns.
- ✓ Ensure that hands, clothing (especially belts) are clear of fan blades and other moving or hot parts of engine. Remove ties and contain long hair.
- \* **DO NOT** smoke or allow a spark or flame in the vicinity of the battery or engine.

#### 1.2. GENERAL SAFETY

- ✓ Familiarise yourself with the application, limitations and potential hazards of the tester. Also refer to the vehicle manufacturer's hand book. **IF IN ANY DOUBT CONSULT A QUALIFIED VEHICLE ELECTRICIAN.**
- ✓ Ensure that the tester is in good condition before use. If in any doubt do not use the unit and contact a qualified vehicle electrician.
- ✓ Only use recommended attachments and parts. To use unapproved items may be dangerous and will invalidate your warranty.
- ✓ Keep tools and other items away from the engine and ensure that you can see the battery and working parts of engine clearly.
- ✓ Determine the system voltage before using the tester.
- ✓ If the tester receives a sharp knock or blow the unit must be checked by a qualified service agent before using.
- ✓ If the battery terminals are corroded or dirty clean them before using the tester.
- ✓ Keep children and unauthorised persons away from the work area.
- \* **DO NOT** disassemble the tester for any reason. The tester must only be checked by qualified service personnel.
- **WARNING!** To prevent the risk of sparking, short circuit and possible explosion **DO NOT** drop metal tools in the battery area, or allow them to touch the battery terminals.
- \* **DO NOT** cross-connect tester to battery. Ensure positive (RED) clamp is to positive terminal and negative (BLACK) clamp is to negative terminal. If battery symbols cannot be distinguished, remember that the negative terminal is the one directly connected to the vehicle bodywork.
- \* **DO NOT** use the tester outdoors, or in damp, or wet locations and **DO NOT** use in the vicinity of flammable liquids or gases.
- ✓ Ensure there is effective ventilation to prevent a build-up of explosive gases.
- \* **DO NOT** use the tester for a task for which it is not designed.
- ✓ When not in use, store the tester carefully in a safe, dry, childproof location.

### 2. INTRODUCTION

Professional diagnosis of battery and alternator faults with the added facility to print the results. Test battery condition with as little as 1.5V of residual charge. No heat, no sparks and no misdiagnosis. Checks condition of alternator, no complicated connections or interpretation required. Analyse the charging system at rest and under load to determine condition of the alternator. Suitable for use on motorcycles, cars (including start/stop) and commercial vehicles. Connect and follow the prompts on the 2-line/16 character LCD screen for straightforward answers. Rugged construction. Supplied in storage case, two rolls of printing paper and instruction manual.

### 3. SPECIFICATION

Model no: .....BT2014  
 Battery: ..... 4 x AA (not supplied)  
 Charging System Capability: ..... 12/24V\*\*  
 Consumable Parts:  
 BT2003.V2-01 - Printing Roll for BT2003, BT2013, BT2014 Pack of 2  
 Minimum Power Requirement: ..... 1.5V  
 Rated Battery Voltage: ..... 6/12V  
 Rating Systems: ..... DIN, EN, IEC, JIS, SAE  
 Voltage Range: ..... 1.5-30V

### 4. OPERATION

4.1. Connect the clamp lead.

4.2. **BEFORE TESTING**

4.2.1. Before you test a battery in a vehicle, turn off the ignition, all accessories and loads. Close all the vehicle doors and the boot/hatch.

4.2.2. Make sure you have put 4 AA 1.5V batteries into the battery chamber on the underside of the tester. Oxyride batteries are NOT recommended because of the initial 1.7 Volt output. If the internal 1.5V batteries run out of power, the display will show "POWER LOW". Replace AA 1.5V batteries before starting a new test.

4.2.3. Note that nothing will be seen on the display until the tester is connected to a vehicle battery.

4.2.4. Make sure the battery terminals are clean. Wire brush them if necessary. Connect the red clamp to the positive battery terminal post; connect the black clamp to the negative battery terminal post.

4.2.5. For the most accurate results, clamp on the lead part of the terminal only. Attaching to the clamp or fixture rather than directly on the terminal will lead to unstable wrong test results.

4.2.6. **Paper load refer to fig.2**

4.2.7. a) Open the clear cover (a).

b) Place a new roll in the paper compartment (b).

c) Paper will be fed automatically when the tester senses a paper roll has been fitted.

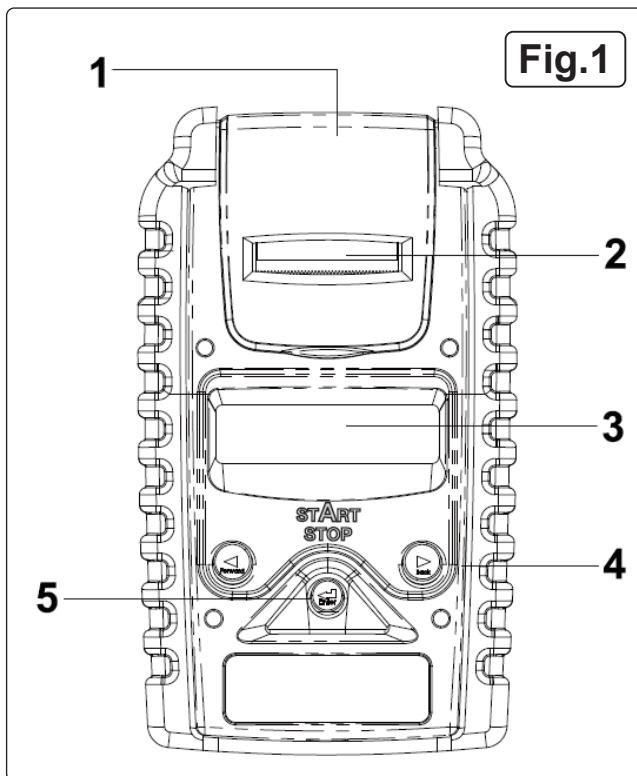

- 1 Paper cover
- 2 Printer
- 3 Display
- 4 Directional keys
- 5 Enter key

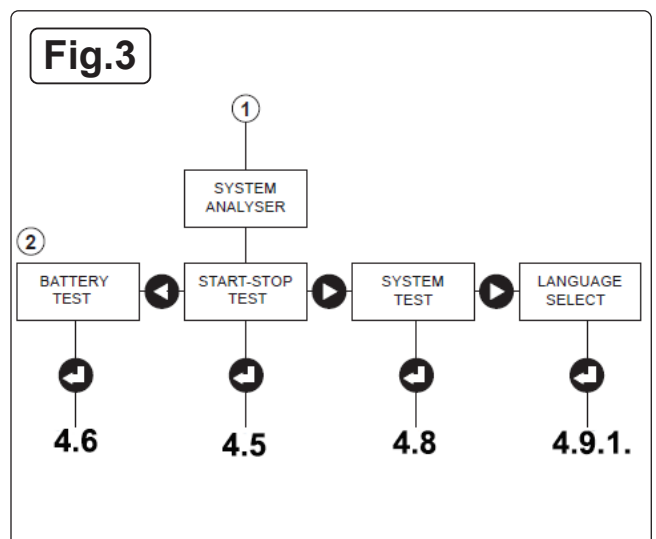
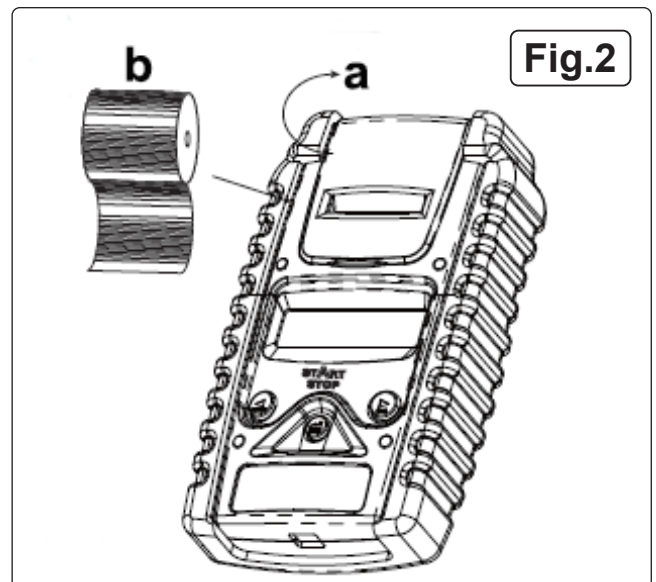

**4.3. QUICK START CHART refer to fig.3**

**4.4.** Switch on the tester by connecting the clamps to the battery.

**4.4.1.** Choose an option from the menu:

**4.5. START\_STOP BATTERY TEST**

**4.5.1.** Press the ◀ ▶ key to select START-STOP Test.

**4.5.2.** In this stage, there are 3 tests for selection.

START-STOP TEST  
BATTERY TEST  
SYSTEM TEST

START-STOP  
TEST

**4.5.3.** Press the ◀ ▶ key to select battery type:

a. EFB (ENHANCED FLOODED)

b. AGM FLAT PLATE

Press «ENTER» to confirm choice.

BATTERY TYPE  
EFB

**4.5.4.** Press the ◀ ▶ key to select battery rating:

SAE (CCA), EN, IEC or DIN. Press «ENTER»  
to confirm choice.

SELECT RATING  
SAE

**4.5.5.** Press the ◀ ▶ key to input the battery capacity:

SAE (CCA): 40~2,000

EN: 40~2,100

DIN: 25~1,300

IEC: 30~1,500

Press «ENTER» to begin test.

SET CAPACITY  
XXXX SAE

**4.5.6.** Press the ◀ ▶ key to confirm the position of the battery if  
the surface charge is detected.

Follow the tester's steps to remove the surface charge if it  
happens.

TEST IN VEHICLE?  
NO

**4.5.7.** Testing battery.

TESTING

**4.5.8.** When test is completed, the display shows the results as following

{Press the ◀ ▶ key to select: SOH (STATE OF HEALTH) or  
SOC (STATE OF CHARGE)}.

**GOOD & PASS**

The battery is good and capable of holding a charge.

GOOD & PASS  
XX.XXV XXXXSAE

**GOOD & RECHARGE**

The battery is good but needs to be recharged.

GOOD & RECHARGE  
XX.XXV XXXXSAE

**RECHARGE & RETEST**

Battery is discharged. The battery condition can not be  
determined until it is fully charged. Recharge and  
retest the battery.

RECHARGE & RETEST  
XX.XXV XXXXSAE

**BAD & REPLACE**

The battery will not hold a charge. It should be replaced  
immediately.

BAD & REPLACE  
XX.XXV XXXXSAE

**BAD CELL & REPLACE**

The battery has at least one cell short circuited. It should be replaced immediately.

BAD CELL & REPLACE  
XX.XXV XXXXSAE

4.5.9. End of test. Print out if required.

**4.6. BATTERY TEST**

4.6.1. Press the ◀ ▶ key to select Battery Test. In this stage, there are 3 tests for selection below.

START-STOP TEST

BATTERY TEST

SYSTEM TEST

Press «ENTER» button to proceed the test for regular starting battery.

BATTERY TEST  
XX.XXV

4.6.2. Press the ◀ ▶ key to select battery type:

a. REGULAR FLOODED

b. AGM FLAT PLATE

c. AGM SPIRAL

d. VRLA/GEL

Press «ENTER» to confirm choice.

BATTERY TYPE  
AGM FLAT PLATE

4.6.3. Press the ◀ ▶ key to select battery rating:

SAE (CCA), EN, IEC, DIN or JIS.

Press «ENTER» to confirm choice.

SELECT RATING  
SAE

4.6.4. Press the ◀ ▶ key to input the battery capacity:

SAE (CCA): 40~2,000

EN: 40~2,100

DIN: 25~1,300

IEC: 30~1,500

JIS: Battery Type No. Press «ENTER» to begin test.

SET CAPACITY  
XXXX SAE

4.6.5. Press the ◀ ▶ key to confirm the position of the battery if surface charge is detected.

Follow the tester's steps to remove the surface charge if it happens. Then testing starts.

TEST IN VEHICLE?  
NO

4.6.6. When test is completed, the display shows the results as following {Press the ◀ ▶ key to select: SOH (STATE OF HEALTH) or SOC (STATE OF CHARGE)}.

**GOOD & PASS**

The battery is good and capable of holding a charge.

GOOD & PASS  
XX.XXV XXXXSAE

**GOOD & RECHARGE**

The battery is good and capable of holding a charge.

GOOD & RECHARGE  
XX.XXV XXXXSAE

**RECHARGE & RETEST**

Battery is discharged. The battery condition cannot be determined until it is fully charged. Recharge and retest the battery.

RECHARGE & RETEST  
XX.XXV XXXXSAE

**BAD & REPLACE**

The battery will not hold a charge. It should be replaced immediately.

BAD & REPLACE  
XX.XXV XXXXSAE

**BAD CELL & REPLACE**

The battery has at least one cell short circuited. It should be replaced immediately.

BAD CELL & REPLACE  
XX.XXV XXXXSAE

4.6.7. End of test. Print out if required.

**4.7. OTHER POSSIBLE DISPLAY MESSAGES****4.7.1. LOAD ERROR**

The tested battery is bigger than 2000SAE (CCA).  
Solution: Check the capacity of the battery.  
The clamp connection is not properly established.  
Make sure the clamp lead is properly connected.

LOAD ERROR

**4.7.2. 24V SYSTEM PRINTING**

To print 24V system test result, user must save the test result first.  
The test result will be recorded until you connect to 12V battery.  
The message to check printout will be displayed after you reconnect to battery.

PRINT 24V SYSTEM  
RESULT? YES

**4.8. SYSTEM TEST**

4.8.1. Press «ENTER» button, you will view the following screen.

SYSTEM TEST  
XX.XXV

4.8.2. Turn off all vehicle accessory loads such as lights, air conditioning, radio, etc. before starting the engine.

4.8.3. When the engine is started, one of the three results will be displayed along with the actual reading measured.

TURN OFF LOADS  
START ENGINE

**CRANKING VOLTS NORMAL**

The system is showing normal draw. Press «ENTER» to perform the charging system test.

CRANKING VOLTS  
XX.XXV NORMAL

**CRANKING VOLTS LOW**

The cranking voltage is below normal limits, troubleshoot the starter with manufacturer's recommended procedure.

CRANKING VOLTS  
XX.XXV LOW

**CRANKING VOLTS NOT DETECTED**

Cranking voltage is not detected.

CRANKING VOLTS  
NOT DETECTED

4.8.4. If the cranking voltage is normal, press «ENTER» to begin charging system test.

PRESS ENTER FOR  
= CHARGING TEST =

4.8.5. Press the «ENTER» key, you will view the following screen.

MAKE SURE ALL  
LOADS ARE OFF

4.8.6. Press the «ENTER» key, one of the three results will be displayed along with the actual reading measured.

**LOW CHARGING VOLTS WHEN TESTING AT IDLE**

The alternator is not providing sufficient current to the battery.  
Check the belts to ensure the alternator is rotating with engine running. If the belts are slipping or broken, replace the belts and retest.

Check the connections from the alternator to the battery.

ALT. IDLE VOLTS  
XX.XXV LOW

If the connection is loose or heavily corroded, clean or replace the cable and retest. If the belts and connections are in good condition, replace the alternator.

**CHARGING SYSTEM NORMAL WHEN TESTING AT IDLE**

The system is showing normal output from the alternator. No problem is detected.

ALT. IDLE VOLTS  
XX.XXV          NORMAL

**HIGH CHARGING VOLTS WHEN TESTING AT IDLE**

The voltage output from the alternator to the battery exceeds the normal limits of a functioning regulator. Check to ensure there is no loose connection and the ground connection is normal. If there is no connection issue, replace the regulator. Since most alternators have the regulator built-in, this will require you to replace the alternator. The normal high limit of a typical automotive regulator is 14.7 volts +/- 0.05. Check manufacturer specifications for the correct limit, as it will vary by vehicle type and manufacturer.

ALT. IDLE VOLTS  
XX.XXV          HIGH

4.8.7. Following the charging system at idle, press «ENTER» for the charging system with accessory loads. Turn on the heater to high (heat), high beam headlights, and rear demister (if equipped). Do not use cyclical loads such as air conditioning or windshield wipers.

TURN ON LOADS  
AND PRESS ENTER

4.8.8. When testing older model diesel engines, the users need to run up the engine to 2500 rpm for 15 seconds. The following screen will be displayed:

RUN ENGINE UP TO  
2500RPM 15 SEC.

4.8.9. Press «ENTER» to look for the amount of ripple from the charging system to the battery. One of two testing results will be displayed along with the actual testing measured.

**RIPPLE DETECTED NORMAL**

Diodes functioning well in the alternator/stator

RIPPLE DETECTED  
XX.XXV          NORMAL

OR

NO RIPPLE DETECTED

**EXCESS RIPPLE DETECTED**

One or more diodes in the alternator are not functioning or there is stator damage. Check to ensure the alternator mounting is sturdy and that the belts are in good shape and functioning properly. If the mounting and belts are good, replace the alternator.

RIPPLE DETECTED  
XX.XXV          HIGH

4.8.10. Press the «ENTER» key to continue the charging system with accessory loads. One of the three results will be displayed along with the actual testing measured.

**CHARGING SYSTEM HIGH WHEN TESTED WITH ACCESSORY LOADS**

The voltage output from the alternator to the battery exceeds the normal limits of a functioning regulator. Check to ensure there are no loose connections and that the ground connection is normal. If there are no connection issues, replace the regulator. Since most alternators have the regulator built-in, this will require you to replace the alternator.

ALT. LOAD VOLTS  
XX.XXV          HIGH

#### CHARGING SYSTEM LOW WHEN TESTED WITH ACCESSORY LOADS

The alternator is not providing sufficient current for the system's electrical loads and the charging current for the battery. Check the belts to ensure the alternator is rotating with the engine running. If the belts are slipping or broken, replace the belts and retest. Check the connections from the alternator to the battery. If the connection is loose or heavily corroded, clean or replace the cable and retest. If the belts and connections are in good working condition, replace the alternator.

ALT. LOAD VOLTS  
XX.XXV                  LOW

#### CHARGING SYSTEM NORMAL WHEN TESTED WITH ACCESSORY LOADS

The system is showing normal output from the alternator. No problem detected.

ALT. LOAD VOLTS  
XX.XXV                  NORMAL

#### 4.9. SETTINGS AND INFORMATION RETRIEVAL

##### 4.9.1. LANGUAGE SELECTION

- 4.9.1.1. Connect the tester to a battery.
- 4.9.1.2. The tester defaults to the BATTERY TEST display. Press the directional keys to the LANGUAGE SELECT display.
- 4.9.1.3. Press ENTER and the display will show the language options. Press the directional keys to select the language you want the tester to display.
- 4.9.1.4. Press ENTER and the display returns to BATTERY TEST.

## 5. MAINTENANCE

- 5.1. Clean tester with a damp soft cloth **DO NOT** use solvents.

Parts support is available for this product. Please email [sales@sealey.co.uk](mailto:sales@sealey.co.uk) or telephone 01284 757500



#### ENVIRONMENT PROTECTION

Recycle unwanted materials instead of disposing of them as waste. All tools, accessories and packaging should be sorted, taken to a recycling centre and disposed of in a manner which is compatible with the environment. When the product becomes completely unserviceable and requires disposal, drain any fluids (if applicable) into approved containers and dispose of the product and fluids according to local regulations.



#### WEEE REGULATIONS

Dispose of this product at the end of its working life in compliance with the EU Directive on Waste Electrical and Electronic Equipment (WEEE). When the product is no longer required, it must be disposed of in an environmentally protective way. Contact your local solid waste authority for recycling information.

**Note:** It is our policy to continually improve products and as such we reserve the right to alter data, specifications and component parts without prior notice.

**Important:** No Liability is accepted for incorrect use of this product.

**Warranty:** Guarantee is 12 months from purchase date, proof of which is required for any claim.

Sealey Group, Kempson Way, Suffolk Business Park, Bury St Edmunds, Suffolk. IP32 7AR



01284 757500



01284 703534



[sales@sealey.co.uk](mailto:sales@sealey.co.uk)



[www.sealey.co.uk](http://www.sealey.co.uk)