



# 20V 25CM CORDLESS CHAINSAW - BODY ONLY

MODEL NO: CP20VCHS

Thank you for purchasing a Sealey product. Manufactured to a high standard, this product will, if used according to these instructions, and properly maintained, give you years of trouble free performance.

**IMPORTANT:** PLEASE READ THESE INSTRUCTIONS CAREFULLY. NOTE THE SAFE OPERATIONAL REQUIREMENTS, WARNINGS & CAUTIONS. USE THE PRODUCT CORRECTLY AND WITH CARE FOR THE PURPOSE FOR WHICH IT IS INTENDED. FAILURE TO DO SO MAY CAUSE DAMAGE AND/OR PERSONAL INJURY AND WILL INVALIDATE THE WARRANTY. KEEP THESE INSTRUCTIONS SAFE FOR FUTURE USE.



Refer to instructions



Wear eye protection



Wear protective gloves



Wear head protection



Wear ear protection



Wear protective clothing



Wear safety footwear



Wear face mask

## 1. SAFETY

- ❑ **WARNING!** Read all safety warnings, instructions, illustrations and specifications provided with this tool. Failure to follow all instructions listed below may result in electric shock, fire and/or serious injury.
- ❑ **WARNING!** Disconnect the saw from the battery unit before changing accessories, servicing, performing any maintenance or storing.
- 1.1. **GENERAL SAFETY**
  - ❑ Maintain the saw and battery to ensure they are kept in good condition. Check for alignment or binding of moving parts and any other condition that may affect the power tool's operation. If damaged, have the tool repaired before use.
  - ✓ Replace or repair damaged parts. Use an authorised service agent and recommended parts only. Unauthorised parts may be dangerous and will invalidate the warranty.
  - ✓ Ensure the saw is switched off before installing the battery pack.
  - ✓ Keep the saw clean for best and safest performance.
  - ✓ Dress properly. Remove ill fitting clothing. Remove ties, watches, rings and other loose jewellery and contain long hair.
  - ✓ Evaluate your working area before using the tool e.g. wood may contain nails, screws etc.
  - ✓ Keep work area clean and well lit.
  - ✓ Keep children and bystanders away while operating a power tool.
  - ✓ Ensure battery pack is correctly inserted into the tool handle and latched in place before attempting to switch it on.
  - ✓ Secure loose work pieces with a clamp, vice or other adequate holding device.
  - ✓ Stay alert, watch what you are doing and use common sense when operating a power tool.
  - ✗ **DO NOT** operate the tool when you are tired or under the influence of alcohol, drugs or intoxicating medication.
  - ✓ Prevent unintentional starting. Ensure the switch is in the off position before connecting the battery pack, picking up or carrying the tool.
  - ✓ Remove any adjusting key or wrench before turning the tool on.
  - ✓ Use personal protective equipment. Always wear eye protection, (standard spectacles are not adequate).
  - ✗ **DO NOT** over reach. Maintain correct balance and footing. Ensure the floor is not slippery and wear non-skid shoes.
  - ✓ Keep children and unauthorised persons away from the working area.
  - ✓ Keep tool and charger in the case and store in a safe, dry, childproof area where the temperature will not exceed 104°F (40°C).
  - ✓ Store idle power tools out of reach of children and **DO NOT** allow persons unfamiliar with the power tool or these instructions to operate the power tool.
  - ✓ Use power tool and accessories in accordance with these instructions, taking into account the working conditions and the work to be performed.
  - ✓ Keep handles and grasping surfaces clean and free from oil and grease.
  - ✗ **DO NOT** force the tool. Use the correct power tool for the application.
  - ✗ **DO NOT** use the tool if the switch does not turn it on and off.
  - ✗ **DO NOT** use the tool where there are flammable liquids, solids or gases, such as paint solvents, etc.
  - ✗ **DO NOT** allow children to operate the tool.
  - ✗ **DO NOT** operate the tool if any parts are missing as this may cause failure and/or personal injury.
  - ✗ **DO NOT** hold unsecured work piece in your hand.
  - ✗ **DO NOT** leave the tool operating unattended.
  - ✗ **DO NOT** carry the tool with your finger on the power switch.
  - ✗ **DO NOT** use the tool for a task it is not designed to perform.
  - ✗ **DO NOT** get the tool or battery charger wet or use in damp or wet locations.
- 1.2. **CHAINSAW SAFETY**
  - ✓ Keep all parts of the body away from the saw chain when the chain saw is operating. Before you start the chain saw, make sure the saw chain is not contacting anything. A moment of inattention while operating chain saws may cause entanglement of your clothing or body with the saw chain.
  - ✓ Always hold the chain saw with your right hand on the rear handle and your left hand on the front handle. Holding the chain saw with a reversed hand configuration increases the risk of personal injury and should never be done.
  - ✓ Hold the chain saw by insulated gripping surfaces only, because the saw chain may contact hidden wiring or its own cord. Saw chains contacting a "live" wire may make exposed metal parts of the chain saw "live" and could give the operator an electric shock.

- ✓ Wear eye protection. Further protective equipment for hearing, face, head, hands, legs and feet is recommended. Adequate protective equipment will reduce personal injury from flying debris or accidental contact with the saw chain.
- ✗ **DO NOT** operate a chain saw in a tree, on a ladder, from a rooftop, or any unstable support. Operation of a chain saw in this manner could result in serious personal injury.
- ✓ Always keep proper footing and operate the chain saw only when standing on fixed, secure and level surface. Slippery or unstable surfaces may cause a loss of balance or control of the chain saw.
- ✓ When cutting a limb that is under tension, be alert for spring back. When the tension in the wood fibres is released, the spring loaded limb may strike the operator and/or throw the chain saw out of control.
- ✓ Use extreme caution when cutting brush and saplings. The slender material may catch the saw chain and be whipped toward you or pull you off balance.
- ✓ Carry the chain saw by the front handle with the chain saw switched off and away from your body. When transporting or storing the chain saw, always fit the guide bar cover. Proper handling of the chain saw will reduce the likelihood of accidental contact with the moving saw chain.
- ✓ Follow instructions for lubricating, chain tensioning and changing the bar and chain. Improperly tensioned or lubricated chain may either break or increase the chance for kickback.
- ✓ Cut wood only. **DO NOT** use chain saw for purposes not intended. For example: **DO NOT** use chain saw for cutting metal, plastic, masonry or non-wood building materials. Use of the chain saw for operations different than intended could result in a hazardous situation.
- ✗ **DO NOT** attempt to use the saw until you have an understanding of the risks and how to avoid them. Serious injury could occur to the operator or bystanders if used improperly.
- ✓ Use of the chain saw for operations different than intended could result in serious injury to the operator or bystanders.

**1.2.1. CAUSES AND OPERATOR PREVENTION OF KICKBACK:**

- ✓ Kickback may occur when the nose or tip of the guide bar touches an object, or when the wood closes in and pinches the saw chain in the cut.
- ✓ Tip contact in some cases may cause a sudden reverse reaction, kicking the guide bar up and back towards the operator.
- ✓ Pinching the saw chain along the top of the guide bar may push the guide bar rapidly back towards the operator.
- ✓ Either of these reactions may cause you to lose control of the saw which could result in serious personal injury. **DO NOT** rely exclusively upon the safety devices built into your saw.
- ✓ As a chain saw user, you should take several steps to keep your cutting jobs free from accident or injury.
- ✓ Kickback is the result of chain saw misuse and/or incorrect operating procedures or conditions and can be avoided by taking proper precautions as given below:
- ✓ Maintain a firm grip, with thumbs and fingers encircling the chain saw handles, with both hands on the saw and position your body and arm to allow you to resist kickback forces. Kickback forces can be controlled by the operator, if proper precautions are taken. **DO NOT** let go of the chain saw.
- ✗ **DO NOT** overreach and do not cut above shoulder height. This helps prevent unintended tip contact and enables better control of the chain saw in unexpected situations.
- ✓ Only use replacement guide bars and saw chains specified by the manufacturer.

**2. INTRODUCTION**

Ideal addition to your garden maintenance tool kit, combining high performance and functionality, featuring quality Oregon bar and chain. Kick back protection with instant chain brake. Tool-less chain tensioning and changing. Automatic chain lubrication and oil level indication display. Composite housing and soft grip handles makes it easy and comfortable to use. Requires compatible 20V battery and mains charger, sold separately.

**3. SPECIFICATION**

**MODEL NO.:**..... **CP20VCHS**  
 Motor Power:.....400W  
 Noise Power/Pressure: ..... 99.4/90.4dB(A)  
 No-Load Speed:..... 3300rpm  
 Bar Length: ..... 25cm  
 Supply:..... 20v  
 Vibration/Uncertainty:..... 6.414/1.5m/s<sup>2</sup>  
 Replacement Saw Chain: .....OREGON Pt. No. 91PX040E

**CONSUMABLES:**  
 Batteries (not included):  
 CP20VBP2 - 2Ah Battery, CP20VBP4 - 4Ah Battery, CP20VBP6 - 6Ah  
 BatteryCharger (not included):  
 CP20VMC

**4. OPERATION**

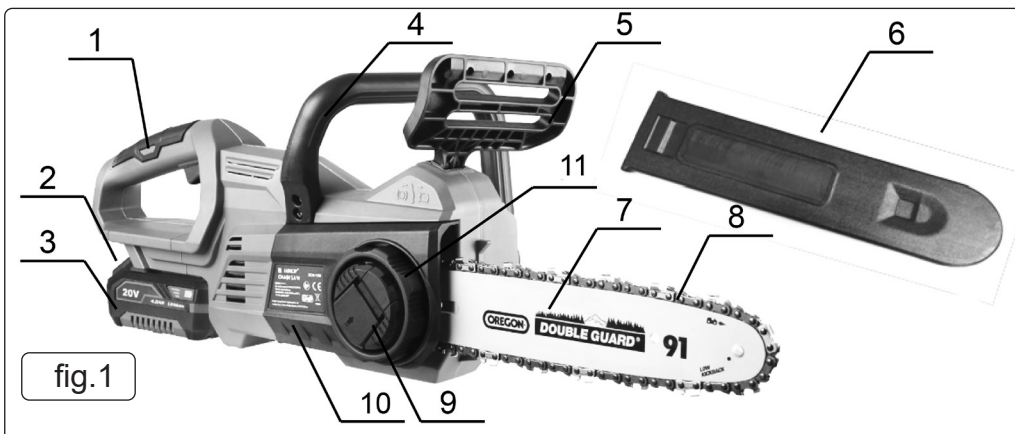

ITEM	DESCRIPTION
1	Rear Handle
2	Battery Release
3	Battery
4	Front Handle
5	Brake Controller
6	Guide Bar Cover
7	Guide Bar
8	Saw chain
9	Lever
10	Sprocket Cover
11	Tension Ring

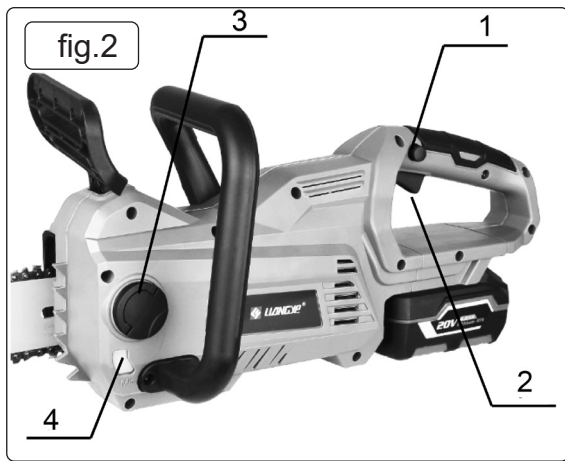

ITEM	DESCRIPTION
1	Lock Off Lever
2	Switch Trigger
3	Oil Tank Cap
4	Oil Tank Window

**NOTE:** The saw is supplied without oil. Fill oil tank before first use (fig.2.3, fig.2.4). See Section 4.6 for details.

- WARNING!** Always be sure that the tool is switched off and the battery cartridge is removed before carrying out any work on the tool.
- WARNING!** Do not touch the saw chain with bare hands. Always wear gloves when handling the saw chain.
- WARNING!** The saw chain and the guide bar are still hot just after the operation. Let them cool down enough before carrying out any work on the tool.

#### 4.1. CHECKING THE CHAIN BRAKE

- WARNING!** Hold the chain saw with both hands when switching it on. Hold the rear handle in one hand and the front handle (fig.1.4) with the other. The bar and the chain must not be in contact with any object.
  - WARNING!** Should the saw chain not stop immediately when this test is performed, the saw may not be used under any circumstances. Consult an authorised service centre.
- 4.1.1. Press the lock-off lever (fig.2.1), then pull the switch trigger (fig.2.2), push the front hand guard (fig.1.5) backwards with your finger at the same time. The saw chain starts immediately.
- 4.1.2. Push the front hand guard (fig.1.5) forwards with the back of your hand. Make sure that the chain saw comes to an immediate standstill.

#### 4.2. CHECKING RUN-DOWN BRAKE

- WARNING!** If the saw chain does not stop within one second in this test, stop using the chain saw and consult an authorised service centre.
- 4.2.1. Run the chainsaw then release the switch trigger completely. The saw chain must come to a standstill within one second.

#### 4.3. REMOVING SAW CHAIN

- 4.3.1. Depress the spring loaded catch and lift the lever up (fig.3.1).
- 4.3.2. Turn lever anticlockwise until the sprocket cover comes away (fig.2.2)
- 4.3.3. Remove the sprocket cover then remove the saw chain and guide bar from the chain saw body.

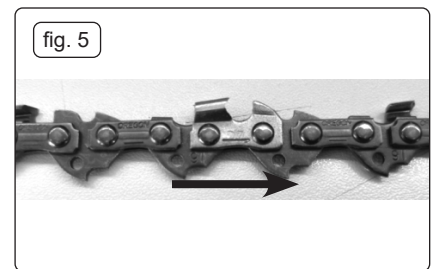
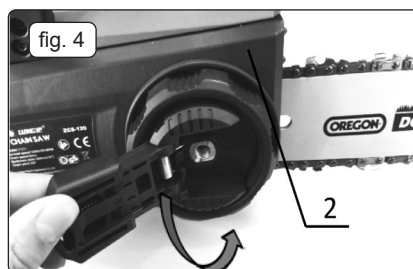
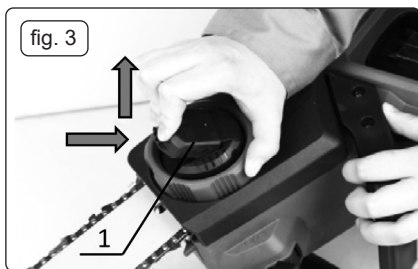

#### 4.4. INSTALLING SAW CHAIN

- 4.4.1. Make sure of the direction of the chain. The arrow mark on the chain shows the direction of the chain (fig.5).
- 4.4.2. Fit in one end of the saw chain on the top of the guide bar and the other end around the sprocket (fig.6).
- 4.4.3. Rest the guide bar in original place on the chain saw.
- 4.4.4. Place the sprocket cover on the chain saw, align the tongue on the sprocket cover with the groove in the housing and slip it into place while matching the log boss on the cover to the corresponding holes at the same time, as shown in fig.7.
- 4.4.5. Depress the sprocket cover and move the guide bar backward or forward until it locks in place with a little click (fig.8)



- 4.4.6. Turn the tension ring (fig.9) clockwise and check the chain tension by pulling the chain away from the guide bar.
- NOTE:** The chain is sharp. Wear suitable gloves while doing this.
- 4.4.7. Keep turning the tension ring clockwise. To check the suitable saw chain tension, pull the saw chain away from the guide bar using force of about 1kg.
- 4.4.8. The optimum gap at this stage is between 5-7mm between the saw chain and guide bar.
- 4.4.9. Turn the lever (fig.11) clockwise until the sprocket cover is secured then return it to the original position.



#### 4.5. ADJUSTING CHAIN TENSION

- NOTE:** Carry out the procedure of installing or removing saw chain in a clean place free from sawdust and possible contaminants i.e. oil.
- NOTE:** Do not over-tighten the saw chain. Excessively high tension of saw chain may cause breakage of saw chain, wear of the guide bar and breakage of the adjusting dial. refer to Section 4.4 for guidance.
- NOTE:** A chain which is too loose can jump off the bar and it may cause an injury
- NOTE:** The saw chain may become loose after many hours of use. From time to time check the saw chain tension before use.
- 4.5.1. Pull the lever up while pressing its edge. Turn it counter-clockwise a little bit to loosen sprocket cover lightly.
- 4.5.2. Turn the tension ring clockwise to tighten the saw chain until the lower side of the saw chain fits in the guide bar rail as illustrated.
- 4.5.3. Keep holding the guide bar lightly and turn the lever clockwise until the sprocket cover is secured.
- 4.5.4. Return the lever to the original position.

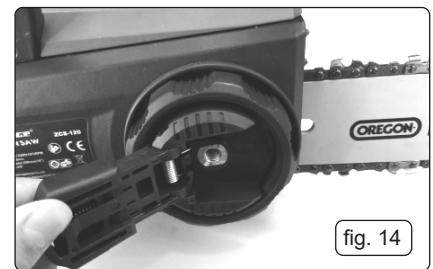
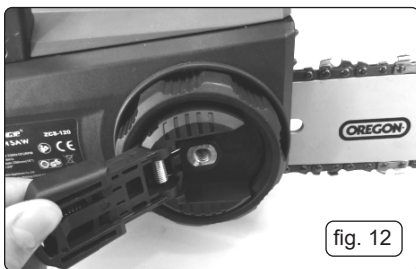

#### 4.6. LUBRICATION

- NOTE:** Use only good quality chain saw oil. See [www.sealey.co.uk](http://www.sealey.co.uk) for further information.
- NOTE:** Check oil level before and during every use. Running with little or no oil will damage the tool.
- 4.6.1. Saw chain is automatically lubricated when the tool is in operation.
- 4.6.2. Check the amount of remaining oil in the oil tank periodically through the transparent oil tank window (fig.2.4).
- 4.6.3. To refill the tank, lay the chain saw on its side, pull up the lever and turn anticlockwise to remove the oil tank cap (fig.2.3).
- 4.6.4. The oil tank capacity is 120ml. After refilling the tank, make sure that the oil tank cap is tightened.

## 5. MAINTENANCE

- NOTE:** Always be sure that the tool is switched off and the battery cartridge is removed before attempting to perform inspection or maintenance.
- NOTE:** Always wear gloves when performing any inspection or maintenance.
- 5.1. CLEANING THE GUIDE BAR (fig.15)**
- 5.1.1. Clean the guide bar whenever the saw chain is sharpened or replaced. See section 4.3, 4.4 for removal.
- 5.1.2. Chips and sawdust will build up in the guide bar groove. This may clog the bar groove and impair the oil flow. Clean out the chips and sawdust every time when you sharpen or replace the saw chain.
- 5.2. CLEANING THE SPROCKET COVER (fig.16)**
- 5.2.1. Chips and saw dust will accumulate inside of the sprocket cover. Remove the sprocket cover and saw chain from the tool then clean the chips and saw dust. See section 4.3, 4.4 for removal.

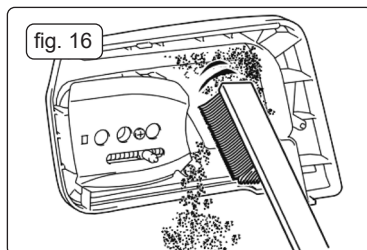
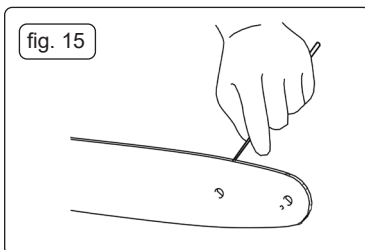

### 5.3. CLEANING THE OIL DISCHARGE HOLE (fig.17)

- 5.3.1. Small dust or particles may be built up in the oil discharge hole during operation. These dust or particles may impair the oil to flow and cause an insufficient lubrication on the whole saw chain. When a poor chain oil delivery occurs at the top of guide bar, clean the oil discharge hole as follows.
- 5.3.2. Remove the sprocket cover and saw chain from the tool. See section 4.3, 4.4 for removal.
- 5.3.3. Remove the small dust or particles using a slotted screwdriver with a slender shaft or the like.
- 5.3.4. Insert the battery cartridge into the tool. Pull the switch trigger to flow built-up dust or particles off the oil discharge hole by discharging chain oil.
- 5.3.5. Remove the battery cartridge from the tool. Reinstall the sprocket cover and saw chain on the tool.

### 5.4. REPLACING THE SPROCKET (fig.18)

**NOTE:** A worn sprocket will damage a new saw chain. Replace the sprocket if damaged.

- 5.4.1. Remove the sprocket cover, saw chain and guide bar. See section 4.3, 4.4 for removal.
- 5.4.2. Refer to fig.X for indication of areas of most wear on sprocket.
- 5.5. Ensure that the circlip is replaced to securely hold the new sprocket safely in place (fig.19).

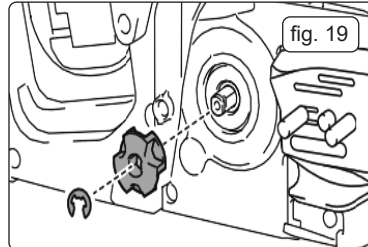
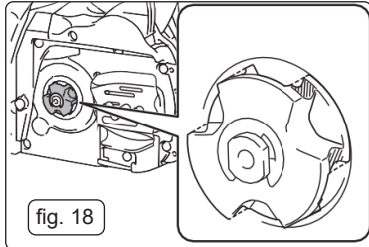

## 6. STORAGE

- 6.1. Clean the tool before storing. Remove any chips and sawdust from the tool after removing the sprocket cover.
- 6.2. After cleaning the tool, run it under no load to lubricate the saw chain and guide bar.
- 6.3. Cover the guide bar with the guide bar cover.
- 6.4. Empty the oil tank.



#### WEEE REGULATIONS

Dispose of this product at the end of its working life in compliance with the EU Directive on Waste Electrical and Electronic Equipment (WEEE). When the product is no longer required, it must be disposed of in an environmentally protective way. Contact your local solid waste authority for recycling information.



#### ENVIRONMENT PROTECTION

Recycle unwanted materials instead of disposing of them as waste. All tools, accessories and packaging should be sorted, taken to a recycling centre and disposed of in a manner which is compatible with the environment. When the product becomes completely unserviceable and requires disposal, drain any fluids (if applicable) into approved containers and dispose of the product and fluids according to local regulations.

**Note:** It is our policy to continually improve products and as such we reserve the right to alter data, specifications and component parts without prior notice.

**Important:** No Liability is accepted for incorrect use of this product.

**Warranty:** Guarantee is 12 months from purchase date, proof of which is required for any claim.

Sealey Group, Kempson Way, Suffolk Business Park, Bury St Edmunds, Suffolk. IP32 7AR



01284 757500



01284 703534



sales@sealey.co.uk



www.sealey.co.uk

## **WARNING! – Risk of Hand Arm Vibration Injury.**

**This tool may cause Hand Arm Vibration Syndrome if its use is not managed adequately.**

This tool is subject to the vibration testing section of the Machinery Directive 2006/42/EC.

This tool is to be operated in accordance with these instructions.

**Measured vibration emission value (a): 6.414m/s<sup>2</sup>**

**Uncertainty value (k): 1.5m/s<sup>2</sup>**

*Please note that the application of the tool to a sole specialist task may produce a different average vibration emission. We recommend that a specific evaluation of the vibration emission is conducted prior to commencing with a specialist task.*

A health and safety assessment by the user (or employer) will need to be carried out to determine the suitable duration of use for each tool.

**NB:** Stated Vibration Emission values are type-test values and are intended to be typical.

Whilst in use, the actual value will vary considerably from and depend on many factors.

Such factors include; the operator, the task and the inserted tool or consumable.

**NB:** ensure that the length of leader hoses is sufficient to allow unrestricted use, as this also helps to reduce vibration.

*The state of maintenance of the tool itself is also an important factor, a poorly maintained tool will also increase the risk of Hand Arm Vibration Syndrome.*

### **Health surveillance.**

We recommend a programme of health surveillance to detect early symptoms of vibration injury so that management procedures can be modified accordingly.

### **Personal protective equipment.**

We are not aware of any personal protective equipment (PPE) that provides protection against vibration injury that may result from the uncontrolled use of this tool. We recommend a sufficient supply of clothing (including gloves) to enable the operator to remain warm and dry and maintain good blood circulation in fingers etc. Please note that the most effective protection is prevention, please refer to the Correct Use and Maintenance section in these instructions. Guidance relating to the management of hand arm vibration can be found on the HSC website [www.hse.gov.uk](http://www.hse.gov.uk) - Hand-Arm Vibration at Work.