



BUTANE INDEXING SOLDERING IRON KIT

3-IN-1

MODEL NO: **AK2971**

Thank you for purchasing a Sealey product. Manufactured to a high standard, this product will, if used according to these instructions, and properly maintained, give you years of trouble free performance.

IMPORTANT: PLEASE READ THESE INSTRUCTIONS CAREFULLY. NOTE THE SAFE OPERATIONAL REQUIREMENTS, WARNINGS & CAUTIONS. USE THE PRODUCT CORRECTLY AND WITH CARE FOR THE PURPOSE FOR WHICH IT IS INTENDED. FAILURE TO DO SO MAY CAUSE DAMAGE AND/OR PERSONAL INJURY AND WILL INVALIDATE THE WARRANTY. KEEP THESE INSTRUCTIONS SAFE FOR FUTURE USE.



Refer to instructions



Wear eye protection



Wear protective gloves



Hot surfaces

1. SAFETY

- WARNING!** Ensure Health & Safety, local authority, and general workshop practice regulations are adhered to when using this equipment, make sure you know where the nearest fire extinguisher is.
- WARNING!** Always wear approved eye/ face protection when operating the torch.
- WARNING! DO NOT** use the torch if you notice that it is damaged or if there could be a gas leak from it.
- WARNING!** Butane gas is extremely flammable, handle with care.
- WARNING!** Always point the torch away from the eyes and body when igniting and during operation.
- WARNING! DO NOT** put the torch down when it is lit, **DO NOT** leave it unattended.
- WARNING!** The flame is not easily visible in bright daylight.
- WARNING!** Ensure the flame is completely extinguished after use. **DO NOT** use water to cool the torch down.
- WARNING!** Only use in a well ventilated area.
- DO NOT** use the torch in an area where paint fumes, solvents or other flammable solids, liquids or gases pose a potential hazard. Keep flammable material away from the torch when operating.
- DO NOT** operate the torch when you are tired or under the influence of alcohol, drugs or intoxicating medication.
- DO NOT** hold any workpiece by hand.
- DO NOT** touch the workpiece close to the heated area as it will be very hot. Allow to cool.
- DO NOT** operate the torch if it is damaged as this may cause failure and/or possible personal injury.
- DO NOT** touch the top of the torch during or immediately after use, as it will be very hot. Allow to cool.
- DO NOT** allow children to operate the torch.
- After use, allow the torch to cool before storing it.
- When not in use, store away from direct sunlight in a safe, dry, childproof location.
- DO NOT** store at over 40°C, such as in a car in hot weather.
- DO NOT** modify the appliance.
- When filled, it will contain flammable gas under pressure.
- DO NOT** puncture or put in fire.
- Make sure the fire is off before refilling.
- DO NOT** keep lit for more than 5 minutes.
- Allow the micro torch to cool down before storage. Storing the appliance in well ventilated area and ensure the flame is over after the operation.
- Use only Sealey original spare parts.
- DO NOT** use torch as a cigarette lighter.
- Be extra careful when using the torch outdoors on sunny or windy days. Wind may carry the torch's heat back toward you or other areas which are not intended to be heated.
- Always check to make sure no unintended parts or materials are being heated.
- Whenever there is a possibility that unintended material has been heated, wait at least two hours before leaving the area.
- DO NOT** inhale soldering fumes.
- Follow refilling procedure to avoid serious accidents.

2. INTRODUCTION

One of a comprehensive range of Premier Hand Tools, suitable for daily professional use. 3-in-1 device that can be used for heating, soldering and shrinking. Fitted with indexing head for three different positions as well as magnetic stand. Powered by butane (lighter fuel) and features a piezoelectric ignition switch. Viewing window at bottom of device to monitor fuel. Flame temperature 1300°C, soldering temperature 450°C and hot air temperature 600°C (Approximately). 60-75 Minute run time with 30ml fuel capacity. Kit Includes; soldering iron, chisel tip, anvil tip, needle tip, hot knife, deflector nozzle, lead free solder, cleansing sponge and tip holder.

3. SPECIFICATION

Model No: AK2971
Temperature range:..... 450-1300°C

4. CONTENTS

- Chisel Tip (1)
- Anvil Tip (2)
- Needle Tip (3)
- Hot Knife (4)
- Heat Shrink Deflector Nozzle (5)
- Lead Free Solder (6)
- Soldering Sponge (7)
- Tip Holder/Cap (8)
- Pointed Tip (9)
- Stand (10)

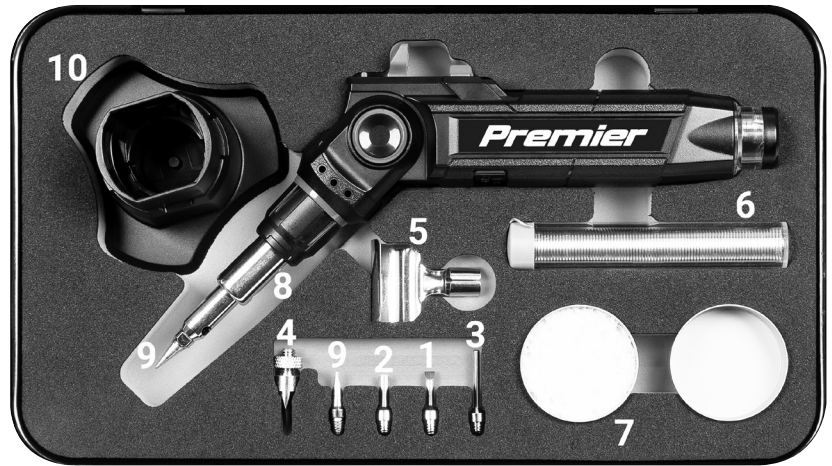

5. OPERATION

- 5.1. The tip of the appliance can be adjusted to 3 different degrees of angle. Press the incline adjustment button (fig.1.1) and position the appliance head according to the desired inclination.
- 5.2. Press the safety lock button (fig.1.2) and at the same time lower the ignition lever (fig.1.3) using your thumb. This action will ignite the appliance.

NOTE: The butane flame may be barely visible in certain light conditions.

- 5.3. Hold the ignition lever (fig.1.3) and release the safety lock button (fig.1.2).
- 5.4. Move the continuous flame switch (fig.1.4) to the right for a constant flame.
- 5.5. Adjust the flame power by moving the adjustment lever (fig.1.5) to the right to increase the power or to the left to decrease it.
- 5.6. To switch off the appliance, move the continuous flame switch (fig.1.4) to the left, this will cut off the gas supply and extinguish the flame.
- 5.7. Ensure flame is extinguished and gas is off after each use.
- 5.8. Stop the operation every 5 minutes to cool the tool.

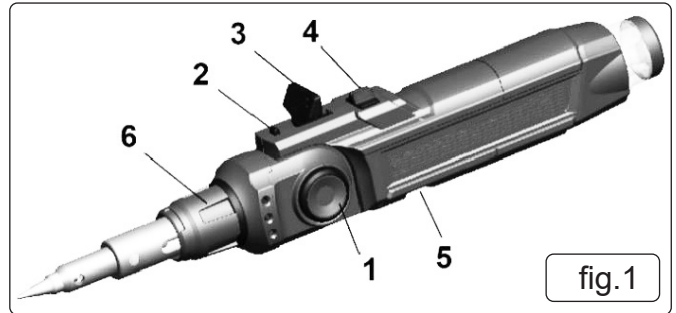

6. MAINTENANCE

6.1. REFILL

- 6.1.1. Fill only with butane gas. It may be hazardous to attempt to fill with other types of gas.
- 6.1.2. Refill in a well-ventilated area, away from flame, combustible materials and other persons.
- 6.1.3. Please make sure the fire is off before refilling.
- 6.1.4. Placing the soldering iron in an upside-down position, Insert the gas canister into the torch refilling valve.
- 6.1.5. Fill slowly. **DO NOT** overfill. When gas starts to Flow out, stop filling
- 6.1.6. After filling, wipe lighter and hands dry before igniting.
- 6.1.7. After refilling operation the gas takes some minutes to stabilize.
- 6.1.8. For next refilling, let the torch cool down for 5 Minutes before filling the tank.

6.2. REPLACEMENT OR INSTALLATION OF INSERTS

- WARNING!** ALWAYS LEAVE TO COOL COMPLETELY THE TOOL BEFORE TO REMOVE OR REPLACE THE INSERTS.
- 6.2.1. Be sure to use the insert right for the job you want.
- 6.2.2. Use only the inserts that fit perfectly on the tool. The inserts that **DO NOT** fit perfectly can result in uncontrolled and dangerous flame. Remove the tip by turning the ring nut (fig.1.6) anticlockwise. Remove the tip and install the desired one. Tighten with the ring nut (fig.1.6) by turning it clockwise.
- 6.2.3. Tighten the inserts securely. For the completely heating of the inserts it is necessary to wait for 25 seconds.

6.3. CLEANING

- 6.3.1. Turn off the soldering iron and let it cool completely before cleaning.
- 6.3.2. The outside unit can be cleaned with a damp cloth with a little mild detergent.
- 6.3.3. Clean the tip on the sponge when it is still warm.



ENVIRONMENT PROTECTION

Recycle unwanted materials instead of disposing of them as waste. All tools, accessories and packaging should be sorted, taken to a recycling centre and disposed of in a manner which is compatible with the environment. When the product becomes completely unserviceable and requires disposal, drain any fluids (if applicable) into approved containers and dispose of the product and fluids according to local regulations.

Note: It is our policy to continually improve products and as such we reserve the right to alter data, specifications and component parts without prior notice.

Important: No Liability is accepted for incorrect use of this product.

Warranty: Guarantee is 12 months from purchase date, proof of which is required for any claim.



REGISTER YOUR PURCHASE HERE

Sealey Group, Kempson Way, Suffolk Business Park, Bury St Edmunds, Suffolk. IP32 7AR



01284 757500



sales@sealey.co.uk



www.sealey.co.uk