

Contents

Symbols used in this manual	15
Symbols on the power tool	15
For your safety	15
Noise and vibration	18
Technical specifications	19
Overview	20
Instructions for use	21
Maintenance and care	24
Disposal information	24
CE Declaration of Conformity	24
UK Declaration of Conformity	25
Exemption from liability	25

Symbols used in this manual



WARNING!

Denotes impending danger. Non-observance of this warning may result in death or extremely severe injuries.



CAUTION!

Denotes a possibly dangerous situation. Non-observance of this warning may result in slight injury or damage to property.



NOTE

Denotes application tips and important information.

Symbols on the power tool



Before switching on the power tool, read the operating manual!



Wear goggles!



Protection class II (completely insulated)



Disposal information for the old machine (see page 24)

For your safety



WARNING!

Before using the angle grinder, please read and follow:

- these operating instructions,
- the “General safety instructions” on the handling of power tools in the enclosed booklet (leaflet-no.: 315.915),
- the currently valid site rules and the regulations for the prevention of accidents.

This angle grinder is state of the art and has been constructed in accordance with the acknowledged safety regulations.

Nevertheless, when in use, the power tool may be a danger to life and limb of the user or a third party, or the power tool or other property may be damaged. The angle grinder may be operated only if it is

- as intended,
- in perfect working order.

Faults which impair safety must be repaired immediately.

Intended use

This angle grinder

- for commercial use in industry and trade,
- is designed for dry grinding and cutting metal and stone; a special cutting guard must be used for cutting,
- for surface grinding with sanding sheets on a backing pad which has been designed to operate at the speed of the machine,
- for use with grinding tools and accessories which are indicated in these instructions or recommended by the manufacturer.

Not permitted are e.g. chain cutting wheels, saw blades.

Safety Warnings for Angle Grinder



WARNING!

Read all safety warnings and all instructions. Failure to follow the warnings and instructions may result in electric shock, fire and/or serious injury. Save all warnings and instructions for future reference.

Safety Warnings Common for Grinding, Sanding or Abrasive Cutting-Off Operations

- **This power tool is intended to function as a grinder, sander or cut-off tool. Read all safety warnings, in-structions, illustrations and specifications provided with this power tool.** Failure to follow all instructions listed below may result in electric shock, fire and/or serious injury.
- **Operations such as wire brushing or polishing are not recommended to be performed with this power tool.** Operations for which the power tool was not designed may create a hazard and cause personal injury.
- **Do not use accessories which are not specifically designed and recommended by the tool manufacturer.** Just because the accessory can be attached to your power tool, it does not assure safe operation.
- **The rated speed of the accessory must be at least equal to the maximum speed marked on the power tool.** Accessories running faster than their rated speed can break and fly apart.
- **The outside diameter and the thickness of your accessory must be within the capacity rating of your power tool.** Incorrectly sized accessories cannot be adequately guarded or controlled.
- **Threaded mounting of accessories must match the grinder spindle thread. For accessories mounted by flanges, the arbour hole of the accessory must fit the locating diameter of the flange.** Accessories that do not match the mounting hardware of the power tool will run out of balance, vibrate excessively and may cause loss of control.
- **Do not use a damaged accessory. Before each use inspect the accessory such as abrasive wheels for chips and cracks, backing pad for cracks, tear or excess wear, wire brush for loose or cracked wires. If power tool or accessory is dropped, inspect for damage or install an undamaged accessory. After inspecting and installing an accessory, position yourself and bystanders away from the plane of the rotating accessory and run the power tool at maximum no-load speed for one minute.** Damaged accessories will normally break apart during this test time.
- **Wear personal protective equipment. Depending on application, use face shield, safety goggles or safety glasses. As appropriate, wear dust mask, hearing protectors, gloves and workshop apron capable of stopping small abrasive or workpiece fragments.** The eye protection must be capable of stopping flying debris generated by various operations. The dust mask or respirator must be capable of filtrating particles generated by your operation. Prolonged exposure to high intensity noise may cause hearing loss.
- **Keep bystanders a safe distance away from work area. Anyone entering the work area must wear personal protective equipment.** Fragments of workpiece or of a broken accessory may fly away and cause injury beyond immediate area of operation.
- **Hold the power tool by insulated gripping surfaces only, when performing an operation where the cutting accessory may contact hidden wiring or its own cord.** Cutting accessory contacting a "live" wire may make exposed metal parts of the power tool "live" and could give the operator an electric shock.
- **Position the cord clear of the spinning accessory.** If you lose control, the cord may be cut or snagged and your hand or arm may be pulled into the spinning accessory.
- **Never lay the power tool down until the accessory has come to a complete stop.** The spinning accessory may grab the surface and pull the power tool out of your control.

- **Do not run the power tool while carrying it at your side.** Accidental contact with the spinning accessory could snag your clothing, pulling the accessory into your body.
- **Regularly clean the power tool's air vents.** The motor's fan will draw the dust inside the housing and excessive accumulation of powdered metal may cause electrical hazards.
- **Do not operate the power tool near flammable materials.** Sparks could ignite these materials.
- **Do not use accessories that require liquid coolants.** Using water or other liquid coolants may result in electrocution or shock.
- **Do not position your body in the area where power tool will move if kickback occurs.** Kickback will propel the tool in direction opposite to the wheel's movement at the point of snagging.
- **Use special care when working corners, sharp edges etc. Avoid bouncing and snagging the accessory.** Corners, sharp edges or bouncing have a tendency to snag the rotating accessory and cause loss of control or kickback.
- **Do not attach a saw chain woodcarving blade or toothed saw blade.** Such blades create frequent kickback and loss of control.

Safety Warnings Specific for Grinding and Abrasive Cutting-Off Operations

Kickback and Related Warnings

Kickback is a sudden reaction to a pinched or snagged rotating wheel, backing pad, brush or any other accessory. Pinching or snagging causes rapid stalling of the rotating accessory which in turn causes the uncontrolled power tool to be forced in the direction opposite of the accessory's rotation at the point of the binding. For example, if an abrasive wheel is snagged or pinched by the workpiece, the edge of the wheel that is entering into the pinch point can dig into the surface of the material causing the wheel to climb out or kick out. The wheel may either jump toward or away from the operator, depending on direction of the wheel's movement at the point of pinching. Abrasive wheels may also break under these conditions. Kickback is the result of power tool misuse and/or incorrect operating procedures or conditions and can be avoided by taking proper precautions as given below.

- **Maintain a firm grip on the power tool and position your body and arm to allow you to resist kickback forces. Always use auxiliary handle, if provided, for maximum control over kickback or torque reaction during start-up.** The operator can control torque reactions or kickback forces, if proper precautions are taken.
- **Never place your hand near the rotating accessory.** Accessory may kickback over your hand.
- **Use only wheel types that are recommended for your power tool and the specific guard designed for the selected wheel.** Wheels for which the power tool was not designed cannot be adequately guarded and are unsafe.
- **The grinding surface of centre depressed wheels must be mounted below the plane of the guard lip.** An improperly mounted wheel that projects through the plane of the guard lip cannot be adequately protected.
- **The guard must be securely attached to the power tool and positioned for maximum safety, so the least amount of wheel is exposed towards the operator.** The guard helps to protect the operator from broken wheel fragments, accidental contact with wheel and sparks that could ignite clothing.
- **Wheels must be used only for recommended applications. For example: do not grind with the side of cut-off wheel.** Abrasive cut-off wheels are intended for peripheral grinding; side forces applied to these wheels may cause them to shatter.
- **Always use undamaged wheel flanges that are of correct size and shape for your selected wheel.** Proper wheel flanges support the wheel thus reducing the possibility of wheel breakage. Flanges for cut-off wheels may be different from grinding wheel flanges.

- **Do not use worn down wheels from larger power tools.** Wheel intended for larger power tool is not suitable for the higher speed of a smaller tool and may burst.

Additional Safety Warnings specific for Abrasive Cutting-Off Operations

- **Do not “jam” the cut-off wheel or apply excessive pressure. Do not attempt to make an excessive depth of cut.**
Overstressing the wheel increases the loading and susceptibility to twisting or binding of the wheel in the cut and the possibility of kickback or wheel breakage.
- **Do not position your body in line with and behind the rotating wheel.** When the wheel, at the point of operation, is moving away from your body, the possible kickback may propel the spinning wheel and the power tool directly at you.
- **When wheel is binding or when interrupting a cut for any reason, switch off the power tool and hold the power tool motionless until the wheel comes to a complete stop.** Never attempt to remove the cut-off wheel from the cut while the wheel is in motion otherwise kickback may occur. Investigate and take corrective action to eliminate the cause of wheel binding.
- **Do not restart the cutting operation in the workpiece. Let the wheel reach full speed and carefully re-enter the cut.** The wheel may bind, walk up or kickback if the power tool is restarted in the workpiece.
- **Support panels or any oversized workpiece to minimize the risk of wheel pinching and kickback.** Large workpieces tend to sag under their own weight. Supports must be placed under the workpiece near the line of cut and near the edge of the workpiece on both sides of the wheel.
- **Use extra caution when making a “pocket cut” into existing walls or other blind areas.** The protruding wheel may cut gas or water pipes, electrical wiring or objects that can cause kickback.

Safety Warnings Specific for Sanding Operations

- **Do not use excessively oversized sanding disc paper. Follow manufacturers recommendations, when selecting sanding paper.** Larger sanding paper extending beyond the sanding pad presents a laceration hazard and may cause snagging, tearing of the disc, or kickback.

Additional safety instructions

- The mains voltage and the voltage specifications on the rating plate must correspond.
- Do not press the spindle lock until the grinding tool stops.

Noise and vibration



NOTE

Values for the A-weighted sound pressure level and for the total vibration values can be found in the “Technical specifications” table.

The noise and vibration values have been determined in accordance with EN 60745.



CAUTION!

The indicated measurements refer to new power tools. Daily use causes the noise and vibration values to change.



NOTE

The vibration emission level given in this information sheet has been measured in accordance with a standardised test given in EN 60745 and may be used to compare one tool with another. It may be used for a preliminary assessment of exposure. The declared vibration emission level represents the main applications of the tool. However if the tool is used for different applications, with different accessories or poorly maintained, the vibration emission may differ. This may significantly increase the exposure level over the total working period.

However if the tool is used for different applications, with different accessories or poorly maintained, the vibration emission may differ. This may significantly decrease the exposure level over the total working period. Identify additional safety measures to protect the operator from the effects of vibration such as: maintain the tool and the accessories, keep the hands warm, organisation of work patterns.

**CAUTION!**

Wear ear protection at a sound pressure above 85 dB(A).

Technical specifications

		L 26-6 230
Machine type		Angle grinder
Max. grinding tool Ø	mm	230
Grinding tool thickness	mm	1–10
Shaft thread	mm	22.23
Spindle thread		M14
Speed	r.p.m.	6,500
Power input	W	2,600
Power output	W	1,800
Weight according to “EPTA Procedure 01/2003” (without power cord)	kg	6.35
Protection class		II/□
A-weighted sound pressure level according to EN 60745 (see “Noise and vibration”):		
Sound pressure level	dB(A)	93
Sound power level	dB(A)	104
Uncertainty	db	1.7
Total vibration value according to EN 60745 (see “Noise and vibration”):		
Emission value a_h when grinding surfaces	m/s^2	6.4
Emission value a_h when cutting-off	m/s^2	6.4
Uncertainty K	m/s^2	1.5

Overview

Different electric power tools are described in these instructions.

The illustrated electric power tool may differ in detail from the one which you purchased.

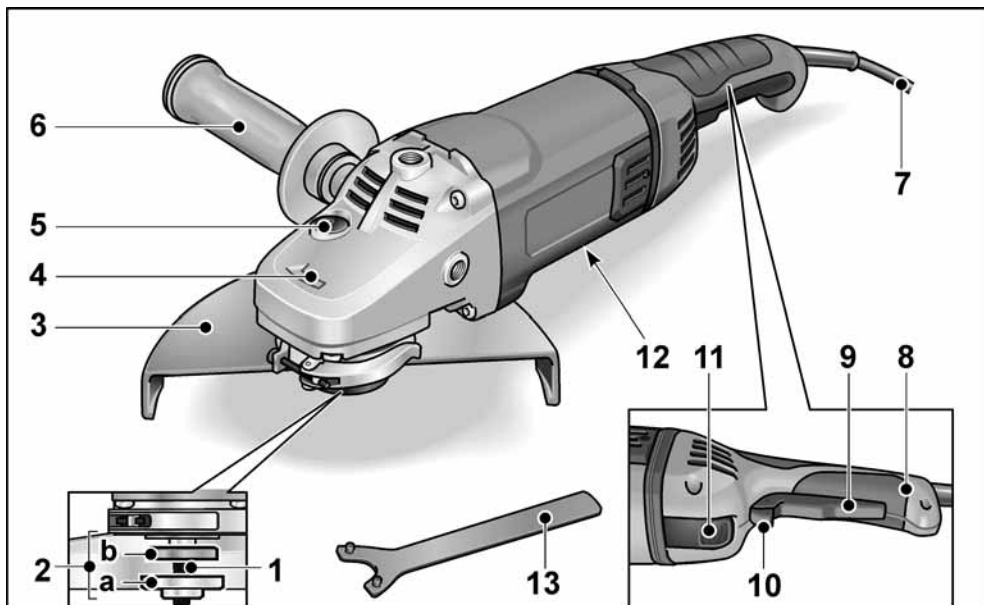

- | | |
|--|---|
| <p>1 Spindle</p> <p>2 Threaded flange
 a Clamping nut
 b Clamping flange</p> <p>3 Quick-release guard</p> <p>4 Gear head
 With air outlet and direction-of-rotation arrow.</p> <p>5 Spindle lock
 Secures the spindle when the tool is changed.</p> <p>6 SoftVib handle
 Side handle can be fitted on the left, the top or the right.</p> <p>7 4.0 m power cord with plug</p> | <p>8 Switch handle</p> <p>9 Switch
 Switches the power tool on and off.</p> <p>10 Starting lockout/Locking button
 Prevents the power tool from starting up unintentionally and locks the switch (9) during continuous operation.</p> <p>11 Release button
 For rotating the switch handle (8) through 90°.</p> <p>12 Rating plate (not illustrated)</p> <p>13 Face spanner</p> |
|--|---|

Instructions for use



WARNING!

Before carrying out any work on the angle grinder, always pull out the mains plug.

Before switching on the power tool

Unpack the angle grinder and check that there are no missing or damaged parts.

Attach the guard



WARNING!

When using the angle grinder for roughing or cutting, never work without the guard. A special cutting guard must be used for cutting.

- Pull out the mains plug.

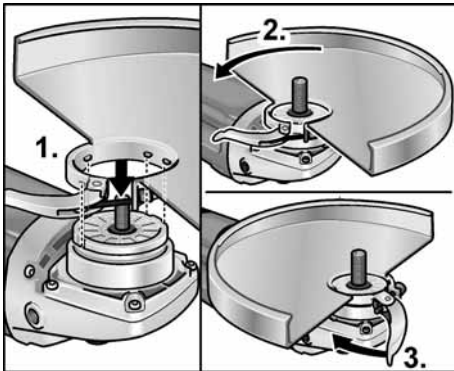

- Connect the guard to the clamping flange with the clamping ring by inserting the cam on the clamping ring into the groove on the flange (1.).
- Rotate guard hood into the required position (2.) and tighten clamping lever (3.).
- Remove in reverse order.

Attach the handle

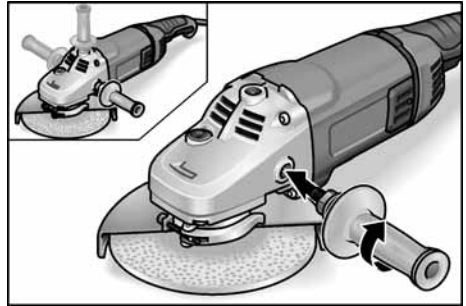

NOTE

It is not permitted to operate the electric power tool without the handle.

Attaching/changing the tool

- Pull out the mains plug.

Attach the grinding wheel

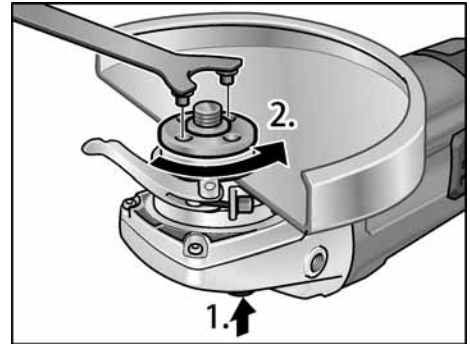

- Press and hold down the spindle lock (1.).
- Using the face spanner, loosen the clamping nut on the spindle in an anti-clockwise direction and remove (2.).

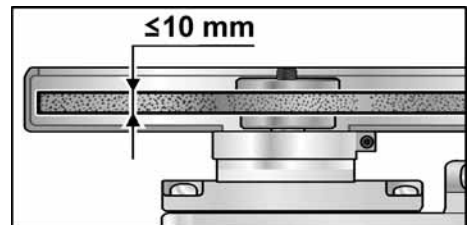

- Insert the grinding wheel in the correct position.

- Screw the clamping nut with flange face up, onto the spindle.
- Press and hold down the spindle lock.
- Tighten the clamping nut with the face spanner.
- Carry out a test run to check that the tool is clamped in the centre.

Attaching the Velcro pad

- Remove the guard.
- Press and hold down the spindle lock (1.).
- Using the face spanner, loosen the clamping nut on the spindle in an anti-clockwise direction and remove.
- Remove clamping flange.

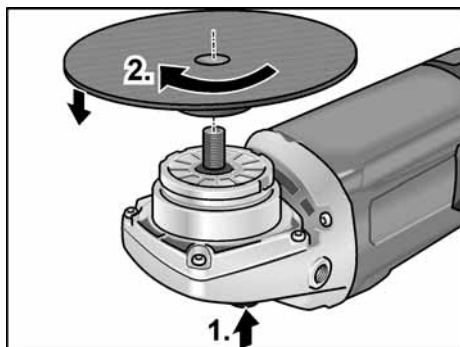

- Screw Velcro pad clockwise onto the spindle and tighten hand-tight (2.).
- Place the sanding tool in the centre of the Velcro pad and press on.
- Carry out a test run to check that the tool is clamped in the centre.

Test run

- Insert the mains plug into the socket.
- Switch on the angle grinder with the switch (without engaging it) and run the angle grinder for approx. 30 seconds. Check for imbalances and vibrations.
- Switch off the angle grinder.

Switching on and off

Brief operation without engaged switch

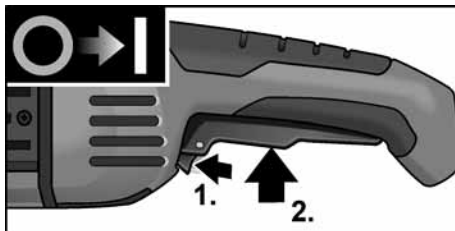

- Press and hold down the starting lockout (1.).
- Press the switch (2.).
- To switch off, release the switch.

Continuous operation with engaged switch

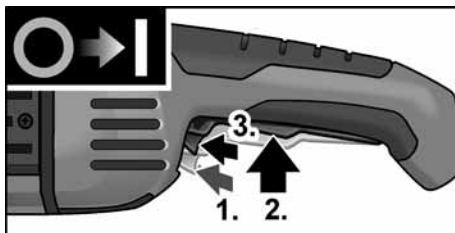

- Press and hold down the starting lockout (1.).
- Press and hold down the switch (2.).
- Press the locking button (3.).

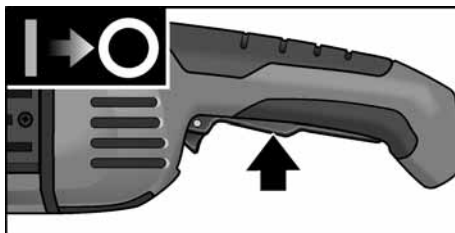

- To switch off, briefly press and release the switch.



NOTE

Following a power failure, the switched on power tool does not restart.

Adjusting the guard



WARNING!

When using the angle grinder for roughing or cutting, never work without the guard. A special cutting guard must be used for cutting.



CAUTION!

Risk of injury! Wear protective gloves.

- Pull out the mains plug.

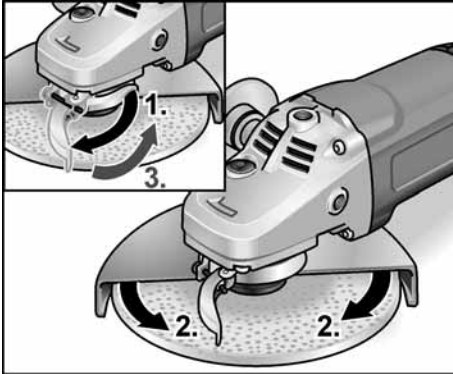

- Loosen the clamping lever (1.).
- Adjust the guard (2.).
- Retighten the clamping lever (3.).

Adjusting the switch handle

The switch handle can be rotated from the middle position by 90° in either direction.

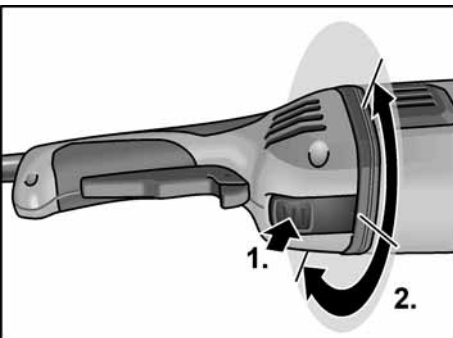

- Press the release button (1.) and simultaneously rotate the switch handle (2.).
- Release the button.
Ensure that the release button is engaged in the respective end position.

Work instructions



NOTE

When the power tool is switched off, the grinding tool continues running briefly.

Rough-grinding



WARNING!

Never use cutting-off wheels for rough-grinding.

- Angle of wheel 20–40° for best cutting performance.
- Applying moderate pressure, move the angle grinder backwards and forwards. As a result, the workpiece will not become too hot and there will be no discoloration; nor will there be any grooves.

Cut-off grinding



WARNING!

A special cutting guard must be used for cutting.

See manufacturer's accessories catalogue.

- Do not press, tilt or oscillate the power tool.
- The angle grinder must always be operated backwards.

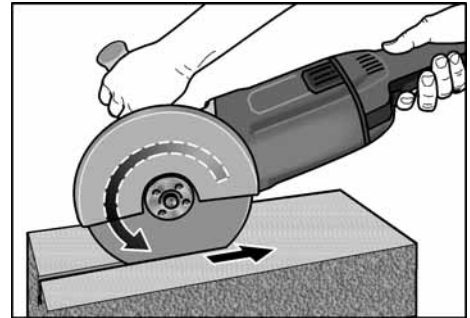

Otherwise, there is a risk of the angle grinder jumping uncontrollably out of the groove.

- Adjust the feed to the material which is to be cut: the harder the material, the slower the feed.

For further information on the manufacturer's products go to www.flex-tools.com.

Maintenance and care

WARNING!

Before carrying out any work on the angle grinder, always pull out the mains plug.

Cleaning

WARNING!

If metals are ground or cut over a prolonged period, conductive dust may become deposited inside the housing. Impairment of the protective insulation! Operate the power tool via a residual-current-operated circuit-breaker (tripping current 30 mA).

- Regularly clean the power tool and ventilation slots. Frequency of cleaning is dependent on the material and duration of use.
- Regularly blow out the housing interior and motor with dry compressed air.

Carbon brushes

The angle grinder features cut-off carbon brushes.

When the wear limit of the cut-off carbon brushes is reached, the angle grinder switches off automatically.

NOTE

Use only original parts supplied by the manufacturer for replacement purposes. If non-original parts are used, the guarantee obligations of the manufacturer will be deemed null and void.

When the power tool is being used, the carbon brushes can be seen sparking through the rear air inlet apertures. If the carbon brushes spark excessively, switch off the angle grinder immediately. Take the angle grinder to a customer service workshop authorised by the manufacturer.

Gears

NOTE

Do not loosen the screws on the gear head during the warranty period. Non-compliance will deem the guarantee obligations of the manufacturer null and void.

Repairs

Repairs may be carried out by an authorised customer service centre only.

Spare parts and accessories

For other accessories, in particular grinding tools, see the manufacturer's catalogues.

Exploded drawings and spare-part lists can be found on our homepage:

www.flex-tools.com

Disposal information

WARNING!

Render redundant power tools unusable by removing the power cord.



EU countries only
Do not throw electric power tools into the household waste!

In accordance with the European Directive 2012/19/EU on Waste Electrical and Electronic Equipment and transposition into national law used electric power tools must be collected separately and recycled in an environmentally friendly manner.

NOTE

Please ask your dealer about disposal options!

CE Declaration of Conformity

We declare under our sole responsibility that the product described under "Technical specifications" conforms to the following standards or normative documents:

EN 60745 in accordance with the regulations of the directives 2014/30/EU, 2006/42/EC, 2011/65/EU.

Responsible for technical documents:
FLEX-Elektrowerkzeuge GmbH, R & D
Bahnhofstrasse 15, D-71711 Steinheim/Murr

Peter Lameli
Technical Head

Klaus Peter Weinper
Head of Quality
Department (QD)

15.12.2020
FLEX-Elektrowerkzeuge GmbH
Bahnhofstrasse 15, D-71711 Steinheim/Murr

UK CA Declaration of Conformity

We as the manufacturer: **FLEX Elektro-
werkzeuge GmbH**,

Business address: **Bahnhofstr. 15,
71711 Steinheim, Germany**

declare under our sole responsibility, that the product(s) described under „Technical specifications“ fulfills all the relevant provisions of **The Supply of Machinery (Safety) Regulations** S.I. 2008/1597 and also fulfills all the relevant provisions of the following UK Regulations:

Electromagnetic Compatibility Regulations S.I. 2016/1091, **The Restriction of the Use of Certain Hazardous Substances in Electrical and Electronic Equipment Regulations** S.I. 2012/3032 and are manufactured in accordance with the following designated Standards: **BS EN 60745-1:2010, BS EN 60745-2-3:2011, BS EN 55014-1:2017, BS EN 55014-2:2015, BS EN 61000-3-2:2014, BS EN 61000-3-3:2013**

Place of declaration: **Steinheim, Germany.**

Responsible person: **Peter Lameli,
Technical Director – FLEX-Elektrowerk-
zeuge GmbH**

Contact details for Great Britain:
FLEX Power Tools Limited,
Unit 8 Anglo Office Park, Lincoln Road,
HP 12, 3RH Buckinghamshire,
United Kingdom.



Peter Lameli
Technical Head

Klaus Peter Weinper
Head of Quality
Department (QD)

19.05.2021

Exemption from liability

The manufacturer and his representative are not liable for any damage and lost profit due to interruption in business caused by the product or by an unusable product.

The manufacturer and his representative are not liable for any damage which was caused by improper use of the product or by use of the product with products from other manufacturers.