

Thank you for purchasing a Sealey product. Manufactured to a high standard, this product will, if used according to these instructions, and properly maintained, give you years of trouble free performance.

IMPORTANT: PLEASE READ THESE INSTRUCTIONS CAREFULLY. NOTE THE SAFE OPERATIONAL REQUIREMENTS, WARNINGS & CAUTIONS. USE THE PRODUCT CORRECTLY AND WITH CARE FOR THE PURPOSE FOR WHICH IT IS INTENDED. FAILURE TO DO SO MAY CAUSE DAMAGE AND/OR PERSONAL INJURY AND WILL INVALIDATE THE WARRANTY. KEEP THESE INSTRUCTIONS SAFE FOR FUTURE USE.



Refer to
Instruction
Manual



Wear eye
protection



Wear protective
gloves



Keep people
away



WARNING!
Crushing
of Hands

1. SAFETY

1.1. GENERAL SAFETY

- WARNING!** Ensure Health & Safety, local authority and general workshop practice regulations are adhered to when using this equipment.
- ✓ Only fully trained and qualified persons should use this equipment. Familiarise yourself with the application and limitations, as well as the specific potential hazards, of the repair kit.
- WARNING!** No part of this unit or any accessory relating to the repair kit is designed for lifting loads. It is intended only as a pushing device and must be used as such, with care.
- WARNING!** Disconnect the repair kit from the hydraulic pump before servicing or performing any maintenance on the unit.
- ✓ Maintain repair kit in good order. Replace/repair with genuine parts only. Unauthorised parts may be dangerous and will invalidate the warranty.
- ✓ Use qualified person to lubricate and maintain the hydraulic pump. **DO NOT** use brake fluid to top up hydraulic unit. Use Sealey hydraulic oil only.
- ✓ Keep the repair kit clean for best and safest performance.
- WARNING!** Ensure you know how much load you are pushing. Never exceed the maximum pushing capacity.
- ✓ Use only with the supplied Sealey hydraulic pump and accessories. Other equipment may damage unit and will invalidate your warranty.
- ✓ The kit accessories may be used with other popular makes of kit.
- ✓ Ensure there is positive engagement of repair kit accessories with the vehicle body before pushing.
- ✓ Maintain correct balance and footing. Ensure the floor is not slippery and wear non-slip shoes.
- ✓ If working on an off centre load, pump with care. If you feel undue resistance, stop and re-adjust the set-up.
- WARNING!** Keep your hands, body and clothing away from the repair kit and accessories when in use. Take any necessary precautions to protect your personal safety and that of others whilst using the repair kit.
- ✓ Ensure the hydraulic hose is not bent or kinked.
- ✓ Keep non-essential persons away from the operating area. Be aware of the locations of other persons assisting you.
- ✓ When releasing tension from the load be sure to undo the hydraulic valve **VERY** slowly.
- ✗ **DO NOT** operate the repair kit if any parts are damaged or missing as this may cause failure and/or personal injury.
- WARNING! DO NOT** use repair kit as a lifting device of any type. **DO NOT** use for any purpose other than for which it is designed.
- ✗ **DO NOT** over extend the ram as the plunger may be forced out of the cylinder.
- ✗ **DO NOT** heat accessories as this may weaken them.
- ✗ **DO NOT** modify accessories for use with this kit.
- ✓ When not in use, place dust cap on end of hydraulic hose and store the kit, in the case, in a safe, dry, childproof location.

2. INTRODUCTION

Heavy gauge snap-together pipework and cast snap-together attachments compatible with most leading makes of snap-together equipment. Supplied with 10 Tonne hand-operated pump, hose, hydraulic ram and storage case.

3. CONTENTS

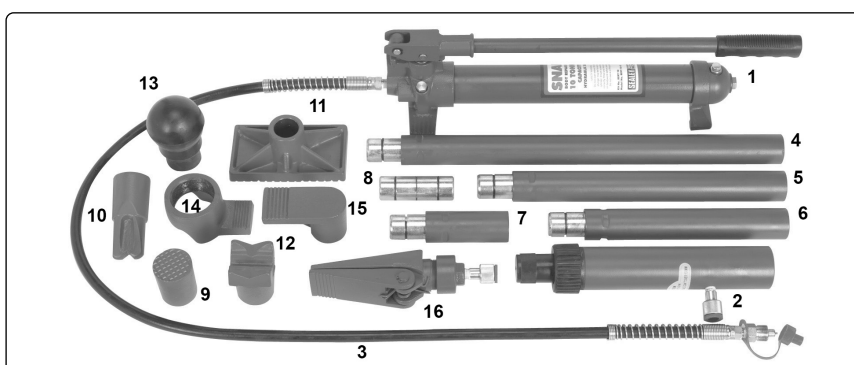

	PART NO.	DESCRIPTION
1	RE97.10-01	Pump assembly
2	RE97.10-02	Ram assembly
3	RE97.10-03	Hose
4	RE97.10-A01	Extension Tube 25.5"
5	RE97.10-A02	Extension Tube 18"
6	RE97.10-A03	Extension Tube 10"
7	RE97.10-A04	Extension Tube 4"
8	RE97.10-A05	Male connector

	PART NO.	DESCRIPTION
9	RE97.10-A06	Serrated saddle
10	RE97.10-A07	Wedge head
11	RE97.10-A08	Flat base
12	RE97.10-A09	90° Combination head
13	RE97.10-A10	Rubber head
14	RE97.10-A11	Ram toe
15	RE97.10-A12	Plunger toe
16	RE97.10-A13	Wedge Ram

4. ASSEMBLY

- 4.1. Unscrew the end plugs from the hose and hydraulic ram. Retain end caps for use when storing the kit.
- 4.2. Screw the hose into the hydraulic ram. Ensure the hose is secure but **DO NOT** overtighten.
- 4.3. Fit the pump handle to the pump unit - **DO NOT** overtighten.
- 4.4. To provide maximum versatility a combination of pump accessories may be used.
- 4.5. To use the flat base plate (item 11) and snap tubing sections (items 4-7) with the hydraulic ram, see Fig.3.

5. OPERATION

- **WARNING!** Ensure you have read and understand Section 1 Safety Instructions.
- 5.1. When using to repair vehicle damage an assessment must be made of all vehicle parts and bodywork distortions. Measurements should be taken and compared with original manufacturer's specifications. Stored energy (memory) in the areas of damage could result in sudden stored energy release, causing body shell movements other than the predicted hydraulic ram stroke.
 - × **DO NOT** commence operation of ram until you are sure of total deflection requirement.
 - 5.2. Comprehensive planning for all operations is essential. Ensure the task undertaken falls within the capacity of the pump and any attachment.
 - 5.3. The pump may be used in any position from horizontal to vertical. When not horizontal ensure the hose end of the pump is downwards.
 - 5.4. To use the pump, close valve (Fig.1) by turning the knob clockwise and open the breather valve (which must be closed when not in use), pump the handle up and down to apply the load.
 - 5.5. To release pump pressure, turn knob anti-clockwise.

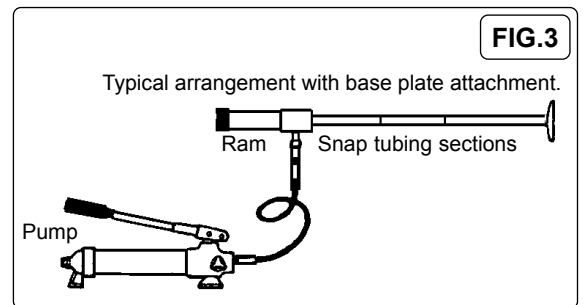
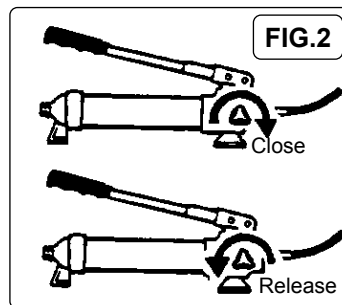
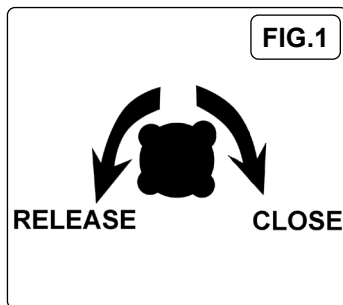

6. ATTACHMENTS

- 6.1. **Hydraulic Ram-** For use in large spaces and where a large amount of force is required. Comes with several attachments.
- 6.2. **Snap Tubing-** Plug into the hydraulic ram in different combinations in order to obtain the required length.
- 6.3. **Serrated Saddle and Wedge Head-** Typically used on the pushing end in frame repair. Can be attached to either the hydraulic ram or extension bars.
- 6.4. **Flat Base-** This is used on the stationary side to spread the force of the hydraulic ram. Can be attached to either the hydraulic ram or extension bars.
- 6.5. **Male Connector-** This is used with the extension bars and other attachments that may be connected to the hydraulic ram.
NOTE: When positioning the hydraulic ram, it is necessary wherever possible to use a smaller attachment on the side that is to be bent or shaped. To further reduce the danger of the stationary side being damaged, place a block of wood or dense hard rubber behind the flat base plate (item 11) in order to cushion the stationary side and spread the pressure exerted by the hydraulic ram.

7. MAINTENANCE

IMPORTANT: Only fully qualified personnel should attempt maintenance or repair of the hydraulic system.

7.1. PUMP OIL LEVEL

Release pressure and disconnect the ram from the pump.
 Hold pump in an upright position.

Ensure the hydraulic ram is fully retracted. Remove the oil reservoir plug (opposite valve) and top up using Sealey hydraulic jack oil (Sealey Part Nos HJO500MLS/HJO5LS). **DO NOT** use brake fluid. After filling, purge the system in order to eliminate any air. Open the release valve (Fig.1.) and pump the handle several times (suggested 20 times). Close the valve and replace the oil reservoir plug. Should the system fail at any time, repeating this process may resolve the problem.

7.2. GENERAL

Before each use check for broken, cracked, bent, loose parts, or any visible damage to welds, ram, pump, hose or accessories. Suspect items to be removed from service and repaired or replaced. Repair or replace with genuine parts only. Unauthorised repairs or parts may be dangerous and will invalidate the warranty.

7.3. DE-COMMISSIONING HYDRAULIC PUMP/RAM

Should the pump or ram become unserviceable, draw off the oil into an approved container and dispose of the product and the oil in accordance with local authority regulations.

Owing to their size and weight, hydraulic products should ideally be repaired by local service agents. We have service / repair agents in most parts of the UK. Before returning your product please call our technical helpline on **01284 757505** for advice and trouble shooting guidance. *If the jack is under guarantee please contact your stockist..*



ENVIRONMENT PROTECTION

Recycle unwanted materials instead of disposing of them as waste. All tools, accessories and packaging should be sorted, taken to a recycling centre and disposed of in a manner which is compatible with the environment. When the product becomes completely unserviceable and requires disposal, drain any fluids (if applicable) into approved containers and dispose of the product and fluids according to local regulations.



REGISTER YOUR
PURCHASE HERE

Note: It is our policy to continually improve products and as such we reserve the right to alter data, specifications and component parts without prior notice. Please note that other versions of this product are available. If you require documentation for alternative versions, please email or call our technical team on technical@sealey.co.uk or 01284 757505.

Important: No Liability is accepted for incorrect use of this product.

Warranty: Guarantee is 12 months from purchase date, proof of which is required for any claim.

Sealey Group, Kempson Way, Suffolk Business Park, Bury St Edmunds, Suffolk. IP32 7AR



01284 757500



sales@sealey.co.uk



www.sealey.co.uk