

Parts Information:
SDS Plus Rotary Hammer Drill 10.8V SV10.8 Series
Model No: CP108VSDSBO

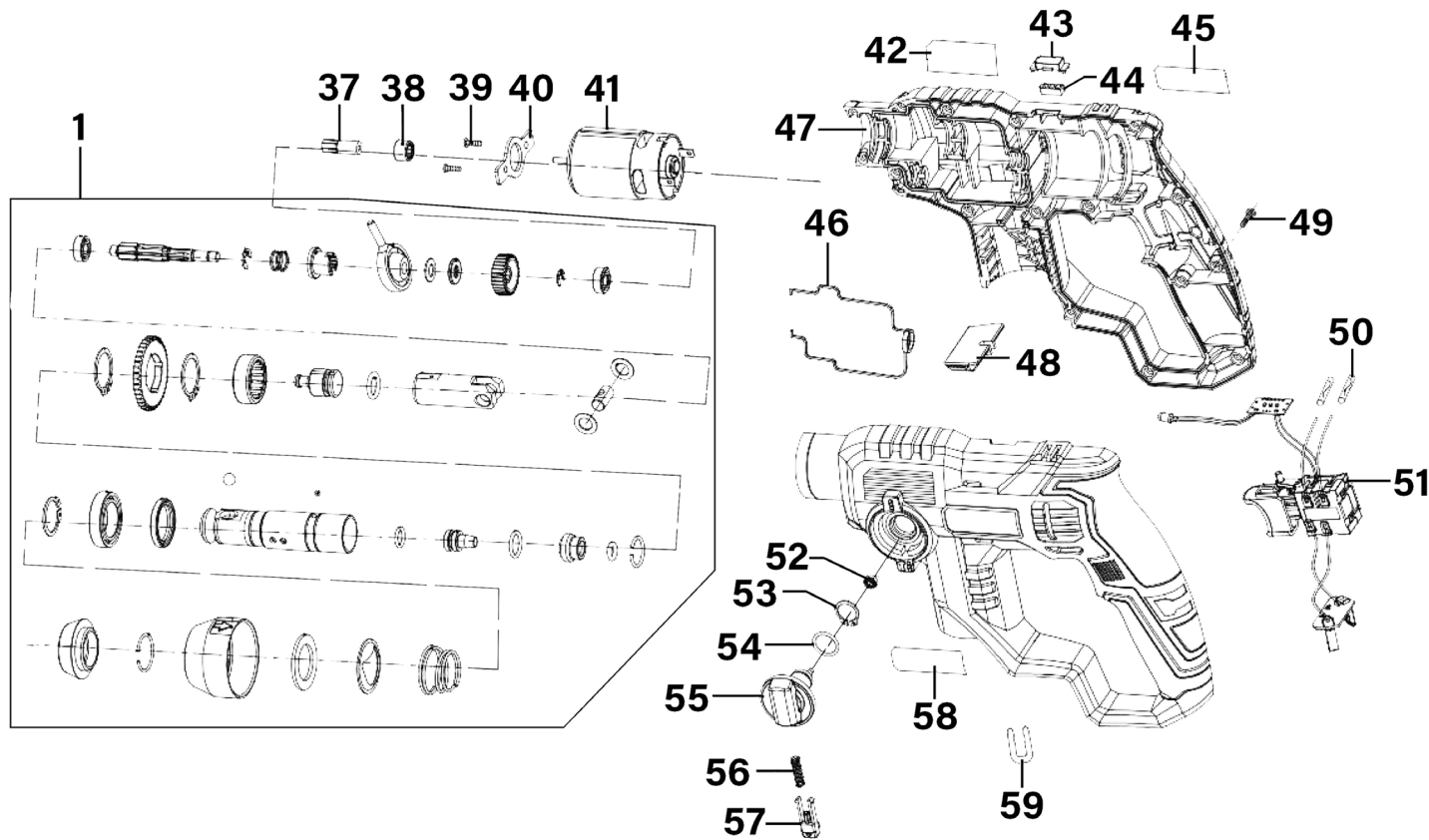

Item	Part No.	Description	Qty
1	CP108VSDSBO-01-36	Hammer Drill/Drive Assembly	1
37	CP108VSDSBO-37	Motor Gear	1
38	B/HK0808	Needle bearing HK0808	1
39	MSC35.S	Csk Phillips Machine Screw M3 X 5 Zinc	2
40	CP108VSDSBO-40	Motor Plate	1
41	CP108VSDSBO-41	Motor	1
42	CP108VSDSBO-42	Label (A)	1
43	CP108VSDSBO-43	Indicator Light Cover (Outer)	1
44	CP108VSDSBO-44	Indicator Light Cover (Inner)	1
45	CP108VSDSBO-45	Warning Label	1
46	CP108VSDSBO-46	Oil-Proof Ring	1
47	CP108VSDSBO-47	Housing Complete	1

Item	Part No.	Description	Qty
48	CP108VSDSBO-48	Forward/Reverse Lever	1
49	CP108VSDSBO-20	Self-Tapping Screw ST2.9 x 14	16
50	CP108VSDSBO-50	Heat Shrink Tube	2
51	CP108VSDSBO-51	Switch Assembly	1
52	CP108VSDSBO-52	Ball Bearing 693Z	1
53	CP108VSDSBO-53	External Circlip	1
54	CP108VSDSBO-54	O-Ring for Rotary Knob	1
55	CP108VSDSBO-55	Rotary Knob Assembly	1
56	CP108VSDSBO-56	Button Spring	1
57	CP108VSDSBO-57	Button	1
58	CP108VSDSBO-58	Label (B)	1
59	CP108VSDSBO-59	Clip (U-Shape)	1

NOTE: It is our policy to continually improve products and as such we reserve the right to alter data, specifications and component parts without prior notice. There may be alternative versions of this product, please contact us should you require this information.

IMPORTANT: No liability is accepted for incorrect use of product. Spare parts must be fitted by a competent person

WARRANTY: Guarantee is 12 months from purchase date, proof of which will be required for any claim.