



# TIMING TOOL KIT - FOR VAG, DODGE, FORD, MITSUBISHI - 1.2D/1.4D/1.6D/1.9D/2.0D - BELT DRIVE

MODEL No: **VSE5951.V2**

Thank you for purchasing a Sealey product. Manufactured to a high standard, this product will, if used according to these instructions, and properly maintained, give you years of trouble free performance.

**IMPORTANT:** PLEASE READ THESE INSTRUCTIONS CAREFULLY. NOTE THE SAFE OPERATIONAL REQUIREMENTS, WARNINGS & CAUTIONS. USE THE PRODUCT CORRECTLY AND WITH CARE FOR THE PURPOSE FOR WHICH IT IS INTENDED. FAILURE TO DO SO MAY CAUSE DAMAGE AND/OR PERSONAL INJURY AND WILL INVALIDATE THE WARRANTY. KEEP THESE INSTRUCTIONS SAFE FOR FUTURE USE.



Refer to Instructions



Wear Eye Protection

## 1. SAFETY

- WARNING!** Wear approved eye protection. Wear appropriate Personal Protective Equipment. A full range of Personal Protective Equipment is available from your Sealey stockist.
- WARNING!** Ensure that Health & Safety, Local Authority Regulations and general workshop practice Regulations are adhered to when using tools.
- × **DO NOT** use tools if damaged.
- ✓ Maintain tools to ensure that they are in an adequate condition for safe use and optimum performance.
- ✓ Ensure that a vehicle that has been raised by a jack is adequately supported. Use axle stands.
- ✓ Wear suitable clothing to avoid snagging. **DO NOT** wear jewellery. Tie back long hair.
- ✓ Account for all tools, parts and components being used. **DO NOT** leave these in or near the engine. Return tools to suitable storage after use.
- ✓ These Instructions are provided as a guide only.
- ✓ Always refer to the vehicle manufactures' service instructions or a proprietary manual to establish the correct procedure and data.
- WARNING!** The warnings, cautions and instructions in this manual cannot cover all possible conditions and situations. The Operator/ user must apply caution and common sense (good practical sense).
- WARNING!** Incorrect or out of phase camshaft timing can result in contact between the valve head and the piston crown. This will cause damage to the engine.

## 2. INTRODUCTION

Comprehensive kit covering engine timing and belt replacement on VAG 1.2-2.0D Pumpe Duse and 1.2, 1.6, 2.0D common rail diesel engines. Also covers these engines fitted in Ford, Dodge and Mitsubishi models. Kit contains crankshaft locking tools for both oval and round crank gears, camshaft locking pins and tensioner adjustment tools. Supplied in storage case.

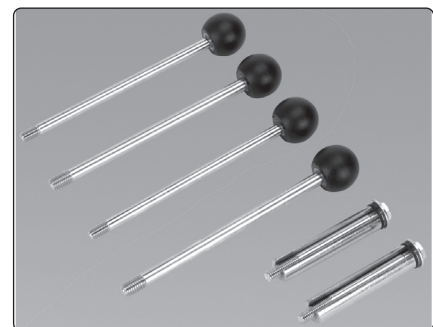
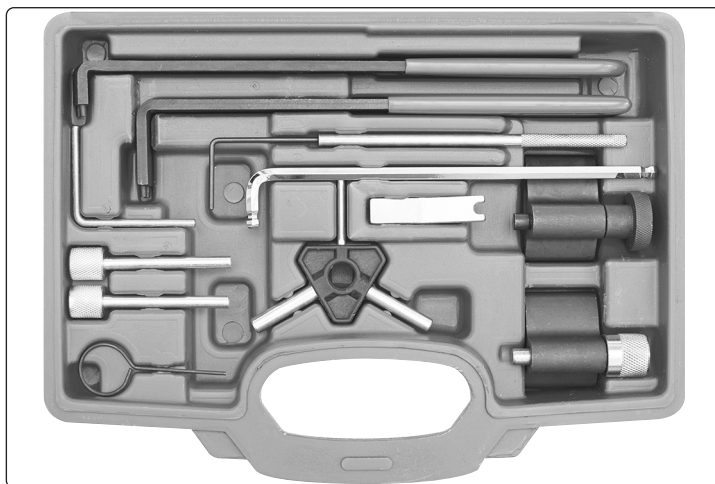

VSE5852 'Service Position' Front End Support Guide Set.

### Associated Tool:

VSE5852 'Service Position' Front End Support Guide Set.

These guides are required to support the front panel when it is extended to provide increased access space in the engine compartment during timing belt replacement eg. on Audi A4, A6, VW Passat, and also to carry out various service applications on a number of other VAG models. OEM Tool Part Numbers: 3369, 3341, U-40050, T10093, T20167, T30092.

### 3. CONTENTS

Item	Part Number	Description	OEM Tool Part Number			
			VAG	Dodge	Ford	Mitsubishi
1	VSE5951-V2-01	Crankshaft Locking Tool (Oval Gears)	T10100	-	-	-
2	VSE5951-V2-02	Crankshaft Locking Tool (Round Gears)	T10050	9883	310-085, 23-059	MB995209
3	VSE5951-V2-03	Camshaft Locking Pin (2 per kit*)	3359, T20102	9882	-	MB995206
4	VSE5951-V2-04	Tensioner Adjuster	3387, U-30009A	-	303-1053	MB995207
5	VSE5951-V2-05	Tensioner Adjuster	T10020	-	-	-
6	VSE5951-V2-06	Tensioner Adjuster	T10264	-	-	-
7	VSE5951-V2-07	Tensioner Locking Tool	T10265	-	-	-
8	VSE5951-V2-08	Tensioner Locking Pin (Mechanical)	T10115	-	303-1054	-
9	VSE5951-V2-09	Tensioner Locking Tool (Hydraulic)	T10008	-	310-084, 23-058	-
10	VSE5951-V2-10	Tensioner Setting Tool (Hydraulic)	-	-	-	-
11	VSE5951-V2-11	Auxiliary Belt Locking Pin	T10060A, T40098, T20167	-	-	-

\*These spares are sold as individual tools - not as pairs or multiples.

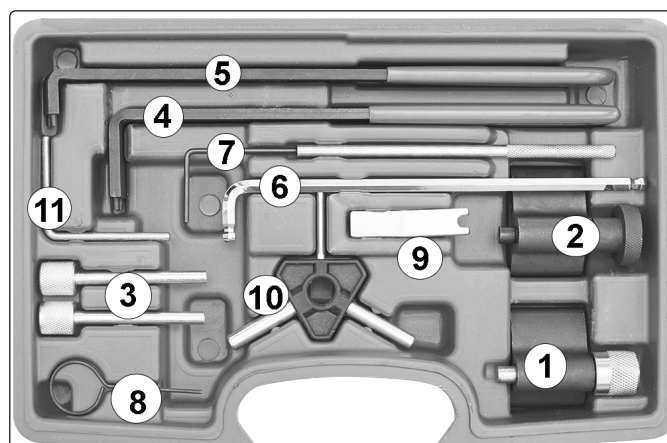

### 4. APPLICATIONS

MAKE	MODEL
<b>Audi</b>	A1/Sportback (10-15), A2 (01-06), A3/Sportback (01-15), A4/Allroad (99-16), A5 (08-12), A5 Sportback (09-15), A5 Cabriolet (12-15), A6/Allroad (98-11), TT (08-14), Q3 (11-15), Q5 (08-15)
<b>Seat</b>	Alhambra (99-15), Altea/Altea XL (04-15), Arosa (99-05), Cordoba (02-09), Exeo (09-14), Ibiza (02-15), Leon (00-12), Toledo (00-11)
<b>Skoda</b>	Fabia (00-07), Fabia II (07-15), Octavia (00-10), Octavia II (04-13), Praktik (10-15), Rapid (12-15), Rapid Spaceback (13-15), Roomster (07-15), Superb (02-08), Superb II (08-15), Yeti (09-12)
<b>VW</b>	Amarok (10-16), Beetle (00-11), Bora (98-08), Caddy/Maxi (03-15), Eos (06-15), Fox (05-11), Golf (98-12), Golf Plus (05-12), Jetta (05-11), Lupo (99-05), Passat/CC (98-15), Polo (99-12), Scirocco (08-12), Sharan (99-15), Tiguan (07-15), Touran (03-15), Transporter (03-19)
<b>Dodge</b>	Caliber (06-11)
<b>Ford</b>	Galaxy (99-06)
<b>Mitsubishi</b>	Grandis (05-10), Lancer (05-10), Outlander (07-10)

#### ENGINE CODES

<b>1.2D TDi PD (Pump Dose)</b>	ANY, AYZ
<b>1.4D TDi PD</b>	AMF, ATL, BAY, BHC, BMS, BNM, BNV, BWB
<b>1.9D TDi PD</b>	AJM, ANU, ARL, ARX, ASZ, ATD, ATJ, AU, AVB, AVF, AVQ, AWX, AXB, AXC, AXR, BJB, BKC, BKE, BLS, BLT, BMT, BPX, BPZ, BRB, BRM, BRR, BRS, BRU, BSU, BSV, BSW, BTB, BUK, BVK, BXE, BXF, BXJ
<b>2.0D TDi PD</b>	AZV, BEW, BKD, BDJ, BDK, BGW, BHW, BKP, BLB, BMA, BMM, BMN, BMP, BMR, BNA, BPW, BRC, BRD, BRE, BRF, BRT, BSS, BST, BUY, BUZ, BVA, BVE, BVF, BVG, BVH, BWV
<b>2.0D Di-D/CRD</b>	ECD(BSY), ECD(BYL), ECE(BWD), BSY, BWC
<b>1.2D TDi CR (Common Rail)</b>	CFWA
<b>1.6D TDi CR</b>	CAYA, CAYB, CAYC, CAYD, CAYE, CLNA
<b>2.0D TDi CR</b>	CAAA, CAAB, CAAC, CAAE, CAGA, CAGB, CAGC, CAHA, CAHB, CBAA, CBAB, CBAC, CBBA, CBBB, CBDA, CBDB, CBDC, CBEA, CCHA, CCHB, CDBA, CDCA, CEGA, CFCA, CFFA, CFFB, CFFD, CFFE, CFGB, CFGC, CFHA, CFHB, CFHC, CFHE, CFHF, CFJA, CGLA, CGLB, CJAA, CJCA, CJCC, CJCB, CJCD, CLCA, CLCB, CLJA, CMEA, CSHA

## 5. INSTRUCTIONS

- 5.1. VSE5951 Setting/Locking Kit provides a comprehensive selection of the timing tools required for engine timing and belt replacement on a huge range of VAG Pumpe Düse and Common Rail diesel engines - 1.2TDi to 2.0TDi.

Many changes have been introduced on these engines since their initial release in 1998, example: "round" or "oval" crankshaft gears. The VSE5951 kit provides tools applicable across this complete range of variants, and therefore it is important that the correct tools are selected from the kit to suit the engine size and variant being worked on.

Always refer to the appropriate service data from the manufacturer and also use the Contents/OE Tool Number cross reference chart provided to identify and select the correct tools from the kit.

### 5.1.1. Variants to watch for.....

#### Crankshaft gears.

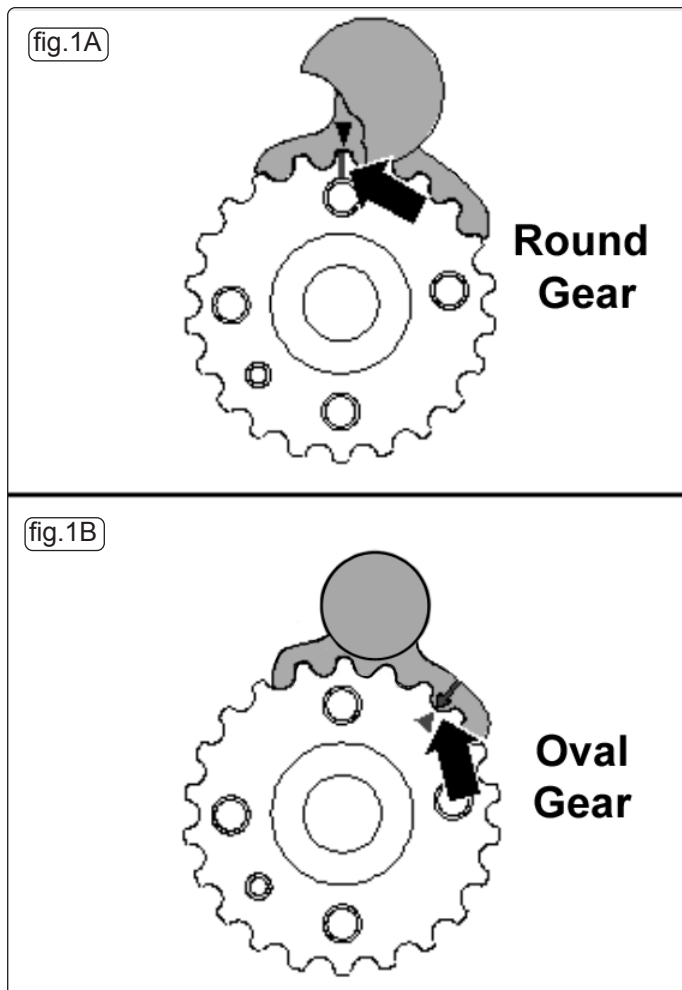

#### Round gear (fig.1A).

VSE5951-V2-02 TDC timing marks align at 12 o'clock position.

#### Oval gear (fig.1B).

VSE5951-V2-01 - TDC timing marks align at 1 o'clock position.

### 5.1.2. Camshaft sprockets.

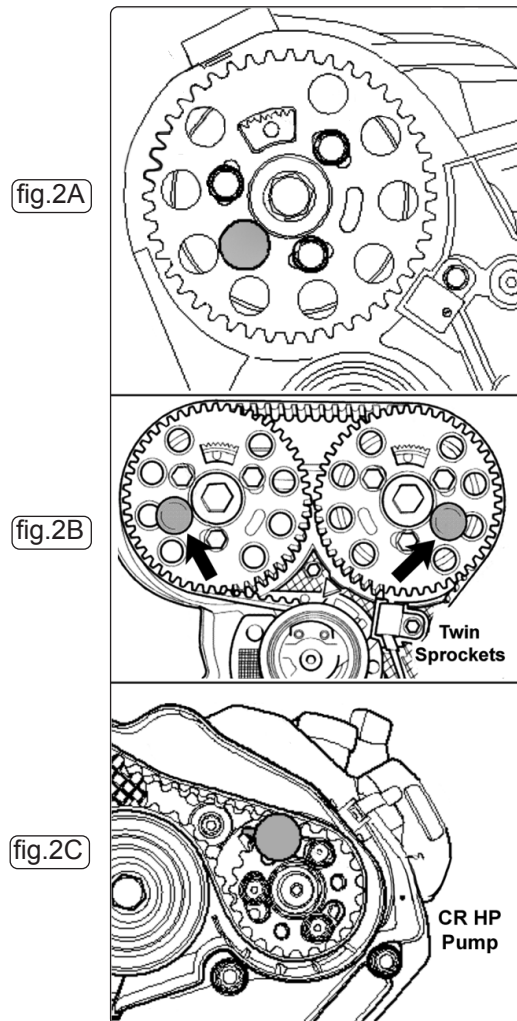

#### VSE5951-V2-03 Locking Pins

(fig.2A) Single sprocket - 1 Pin

(fig.2B) Twin sprockets - 2 Pins

(fig.2C) CR - Single sprocket & HP Pump sprocket - 2 Pins

### 5.1.3. Belt tensioners.

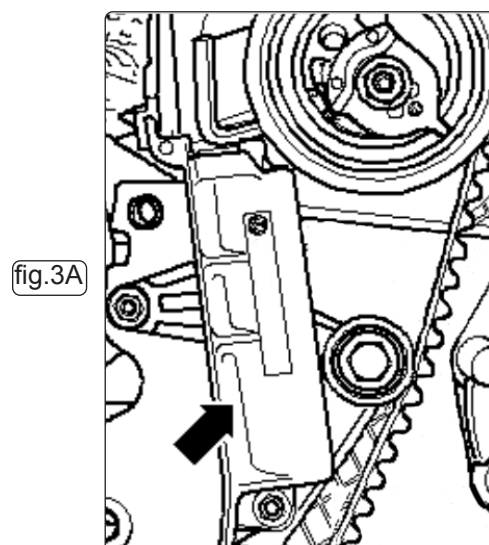

Early engines - hydraulic tensioners (fig.3A)

VSE5951-V2-09 Locking Tool

VSE5951-V2-04 Adjuster

VSE5951-V2-10 Setting Tool

fig.3B

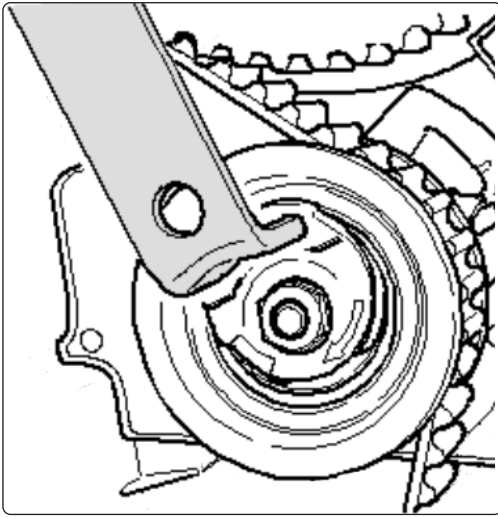

Later engines- mechanical (friction damped) tensioners (fig.3B)

- VSE5951-V2-08 Locking Pin
- VSE5951-V2-04 Adjuster
- VSE5951-V2-05 Adjuster

5.1.4. Larger engine mount – allows removal of belt without removing mount.

fig.4

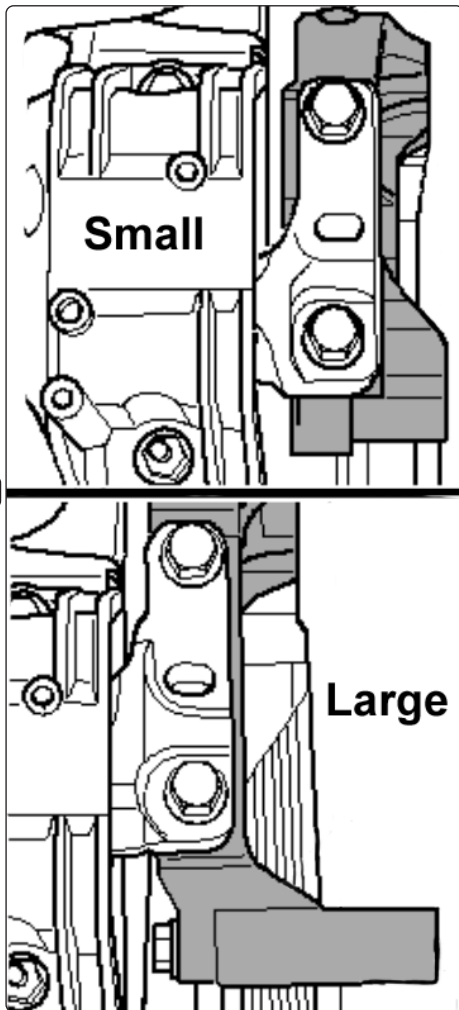

Special tensioner tools required to access tensioner.

- VSE5951-V2-07 Locking Tool
- VSE5951-V2-06 Adjuster

fig.5

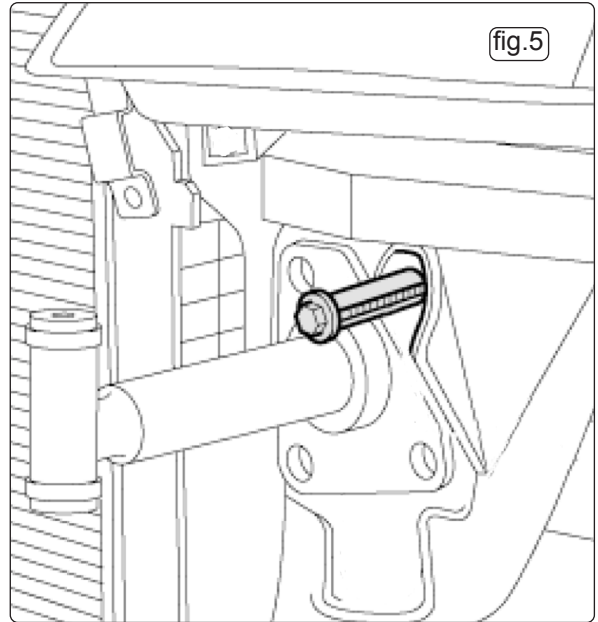

5.2. ASSOCIATED TOOL – VSE5852

'Service Position' Front End Support Guide Set.

These guides are required to support the front panel when it is extended to provide increased access space in the engine compartment during timing belt replacement eg. on Audi A4, A6, VW Passat, and also to carry out various service applications on a number of other VAG models.

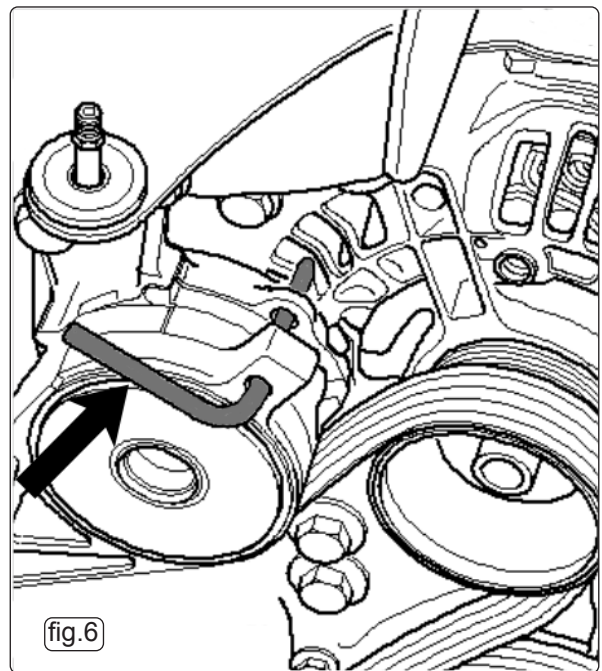

5.3. VSE5951-V2-11 Auxiliary Belt Tensioner Locking Pin.

VSE5951-V2-11 Locking Pin is required to be used on almost all of these engines as the auxiliary tensioner must be 'locked' and removed together with the belt to give access to the timing belt (fig.6).



#### 5.4. Crankshaft timing positions.

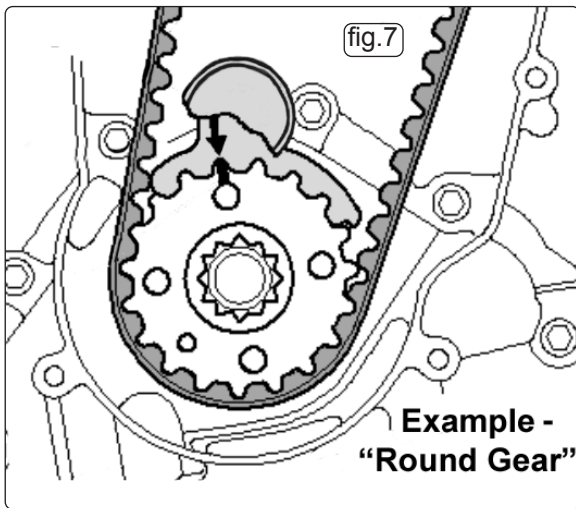

##### 5.4.1. VSE5951-V2-02 and VSE5951-V2-01 Crankshaft locking Tools.

There are two types of crankshaft gear - 'round' or 'oval', and it is imperative that the correct Crankshaft Locking Tool from the VSE5951 kit is selected and used on the appropriate gear. **Using the incorrect Locking Tool will cause engine damage.**

**IMPORTANT:** The crankshaft must be positioned at TDC prior to the tool being fitted. The tool is fitted onto the gear in a position where the timing mark on the Locking Tool is aligned with the mark on the crankshaft gear (fig.7 example - round gear timing mark).

**NOTE:** These tools can only be fitted correctly to the crankshaft gear by sliding the tool into the gear teeth from the front face of the gear. The tool will not locate correctly by being fitted on top of the gear.

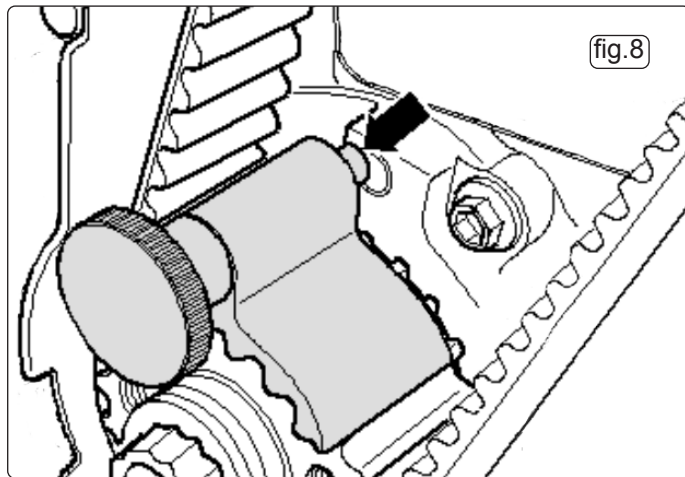

5.4.2. The crankshaft is turned **clockwise** to TDC No.1 cylinder and confirmed by the camshaft sprocket timing marks/ position. The crankshaft is locked in position by sliding the locking tool into the crank gear teeth and at the same time locating the rear lug of the Locking Tool into the hole in the oil seal housing (fig.8).

#### 5.5. Camshaft timing positions.

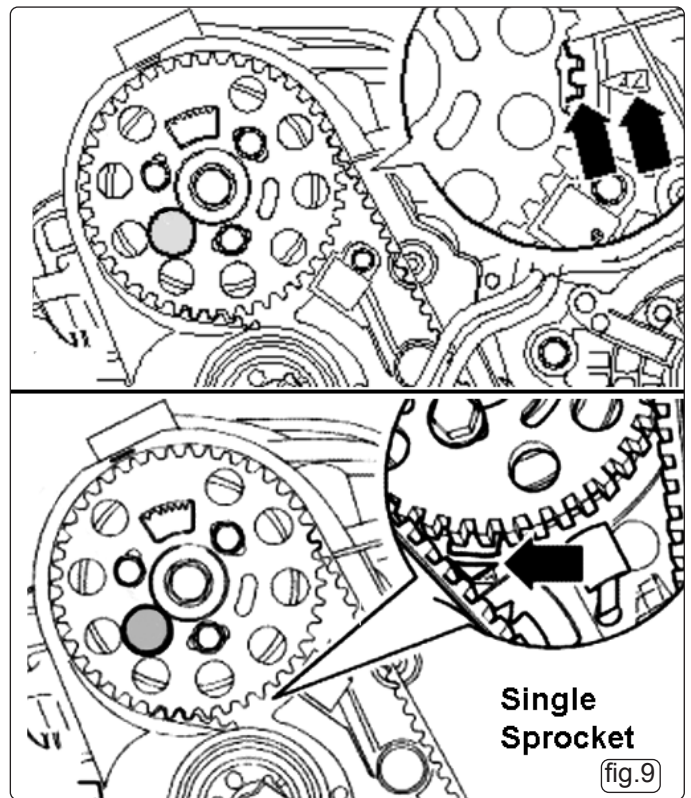

##### 5.5.1. VSE5951-V2-03 Camshaft Locking Pins (2 per kit).

On engines with a single camshaft the timing position is correct when the gear window is at the top and the timing marks (rear belt cover/camshaft sensor wheel) are aligned. Marks can be "3Z" - 3 cyl. engines (on the left side), or "4Z" - 4 cyl. engines (on the right side), or also as shown in fig.9.

5.5.2. The Camshaft Locking Pin (one pin) is inserted into the free hole on the left hand side of the sprocket. To 'lock' the camshaft the Pin is pushed through the sprocket and through the sprocket hub to locate into the timing hole in the cylinder head.

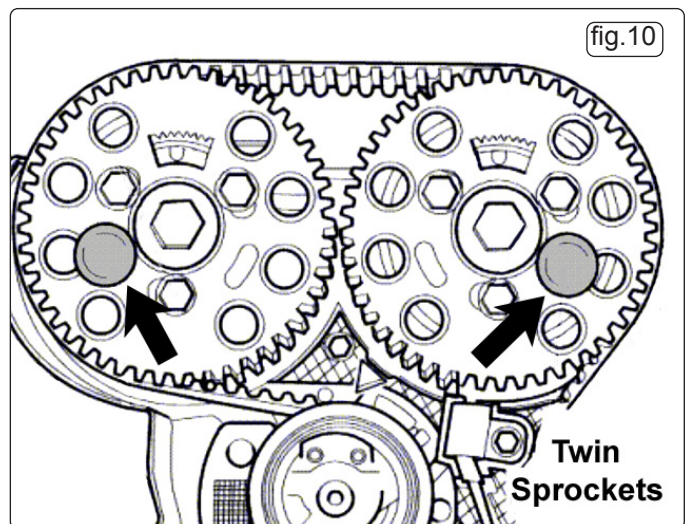

5.5.3. For twin camshaft engines (16v.) timing position is correct when the gear windows are at the top and timing marks on the rear belt cover/camshaft sensor are aligned. The Camshaft Locking Pins (two pins) are inserted into the free holes in each sprocket - the hole on the left hand side of the exhaust camshaft sprocket and the right hand side of the inlet camshaft sprocket. To 'lock' the camshafts the Pins are pushed through the sprockets and through the sprocket hubs to locate into the timing holes in the cylinder head (fig.10).

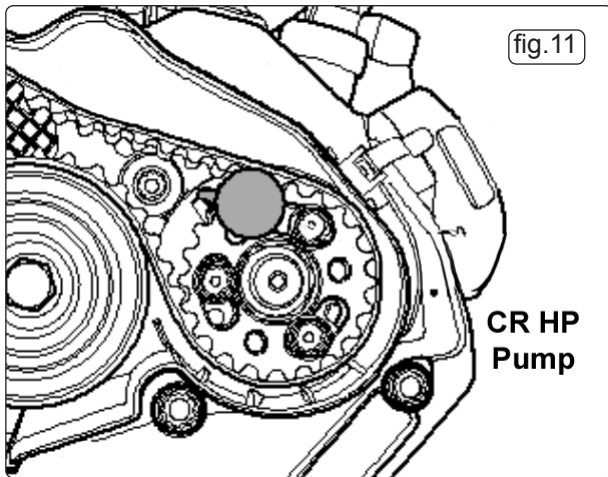

- 5.5.4. On common rail engines both Locking Pins are used. One to 'lock' the camshaft sprocket and the other Pin the 'lock' the HP pump sprocket – also driven by the timing belt.
- 5.5.5. The camshaft timing position is correct when the arrow on the camshaft sprocket is pointing upwards, or the gear window is at the top. The camshaft locking pin is inserted through the sprocket and through the sprocket hub to locate into the timing hole in the cylinder head.
- 5.5.6. The HP pump is 'locked' in position, using the 2nd VSE5951-01 Pin, and then the 3 retaining bolts are released, prior to the new belt being fitted (fig.11) - also see "Timing Belt Installation, Common Rail engines".

#### 5.6. Hydraulic Tensioners – Early Pumpe Düse engines.

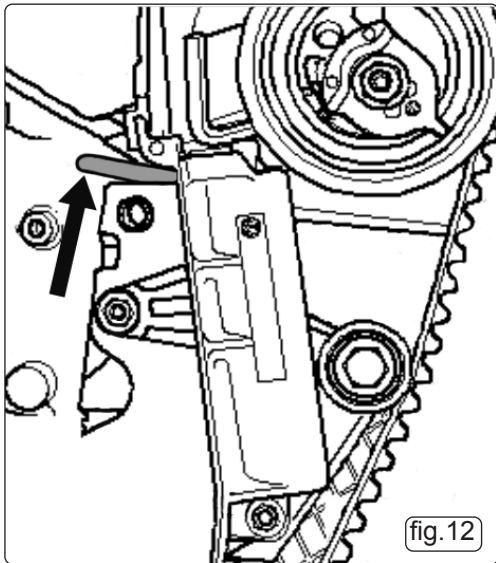

VSE5951-V2-09 Tensioner Locking Tool  
 VSE5951-V2-04 Tensioner Adjuster  
 VSE5951-V2-10 Tensioner Setting Tool

- 5.6.1. Early Pumpe Düse engines have hydraulic (automatic) belt tensioners. In order to release tension for removal of the belt, the tension eccentric is turned **anticlockwise** so to depress the tensioner unit sufficiently to insert VSE5951-V2-09 Locking Tool (fig.12). The tensioner unit can then be removed together with the old timing belt. When installing a new belt the camshaft sprocket bolts are released and the sprocket turned **clockwise** until the bolts are at the end of the elongated holes. Camshaft sprocket bolts should be replaced with new bolts.

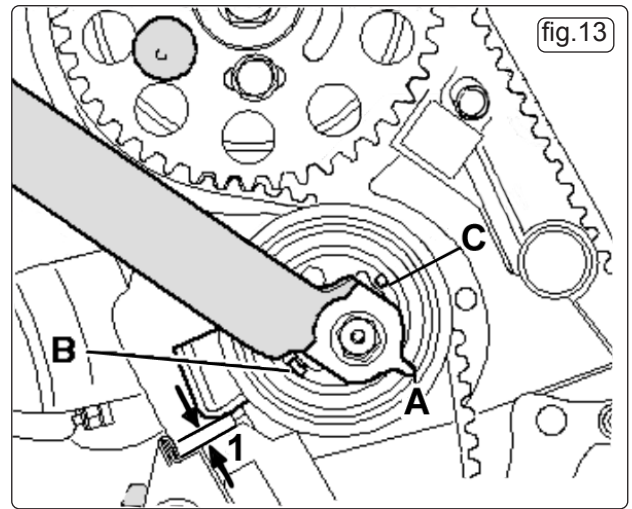

- 5.6.2. Then using VSE5951-V2-04 Adjuster the tensioner eccentric is turned **clockwise** until pointer "A" comes to a stop at position "B" (fig.13). The new timing belt is fitted, ensuring it is taut between sprockets on the non-tensioner side. VSE5951-06 Adjuster is used to turn the eccentric **anticlockwise** towards "C" until VSE5951-V2-09 Locking Tool can be removed. **NOTE:** The eccentric is restrained in this position using VSE5951-V2-04 Adjuster.

#### 5.7. VSE5951-V2-10 Tensioner Setting Tool.

- 5.7.1. VSE5951-07 Setting Tool comprises 4mm, 7mm and 8mm set pins which are used to set the gap on hydraulic tensioners, at position "1" (fig.13). For Pumpe Düse engines the settings are: Engine codes ANY and AYZ 7mm ± 1mm. Engines with hydraulic tensioner EXCEPT codes ANY/AYZ 4mm ± 1mm.
- 5.7.2. The appropriate set pin size is inserted into position "1" and the VSE5951-06 Adjuster allowed to move slowly in a **clockwise** direction adjusting the gap at position "1" to the set pin diameter. The tensioner locking nut is then tightened. The tensioner dimension at position "1" must be checked after tightening the camshaft sprocket bolts, removing **all** locking tools and turning the engine over twice, by hand, and returning to the TDC No.1 cylinder position. **NOTE:** A suitable Holding Tool must be used on the camshaft sprocket when tightening the sprocket bolts.



5.8. Mechanical Tensioners (friction dampened) – Later Pompe Düse engines.

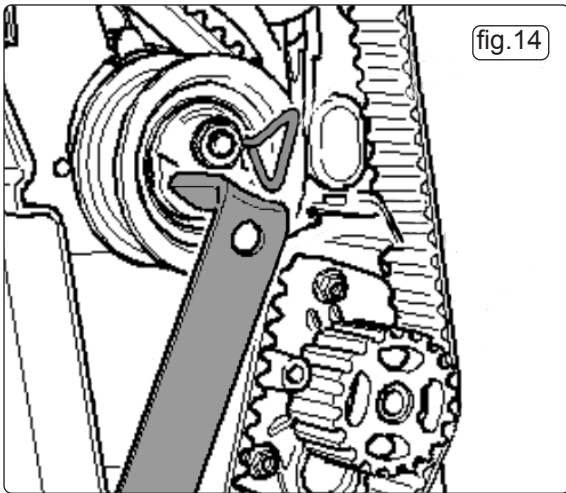

VSE5951-V2-08 Tensioner Locking Pin  
VSE5951-V2-04 Tensioner Adjuster  
VSE5951-V2-05 Tensioner Adjuster

- 5.8.1. Before releasing the tensioner to remove the old timing belt, the crankshaft and camshaft locking tools must be in place and the camshaft sprocket bolts released so that the sprocket(s) can be turned within the elongated holes. **NOTE:** the sprocket(s) should be able to turn but not tilt.
- 5.8.2. The tensioner nut is slacked and either VSE5951-04 or VSE5951-05 Adjuster (whichever suits the application best), is used to turn the tensioner **anticlockwise** until VSE5951-08 Locking Pin can be inserted (fig.14). The tensioner is then turned **clockwise** to the stop and the tensioner nut tightened. The old timing belt can now be removed and the camshaft sprocket(s) turned **clockwise** in the elongated holes in the sprocket(s).
- 5.8.3. It is advisable to check that the tensioner retaining lug is fully engaged into the rear belt cover. The new belt is fitted and the tensioner nut released.

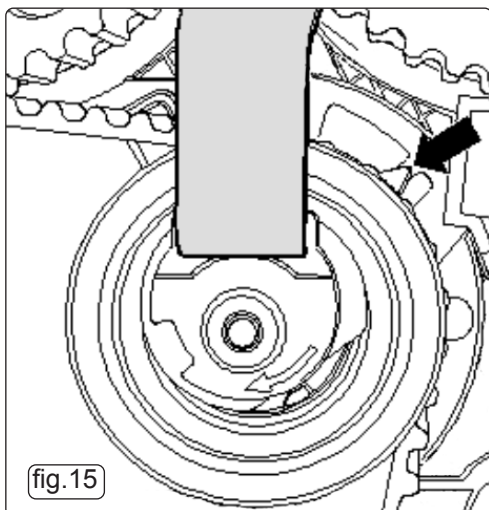

- 5.8.4. The tensioner is turned **anticlockwise** using the Adjuster until the Tensioner Locking Pin can be removed and the tensioner is turned **clockwise** until a position is achieved where the pointer is aligned with the "notch" in the back plate (fig.15).

- 5.8.5. Counter hold the camshaft sprocket(s) with a suitable Holding Tool and tighten the sprocket bolts. **All** locking tools should be removed, the engine turned over twice, by hand, and returned to TDC No.1 cylinder. Check that crankshaft and camshaft timing tools can be easily fitted, and that the tensioner pointer is aligned with the "notch".

5.9. Change of Engine Mounting – Revised belt tensioner - Later Pompe Düse engines/Common Rail engines.

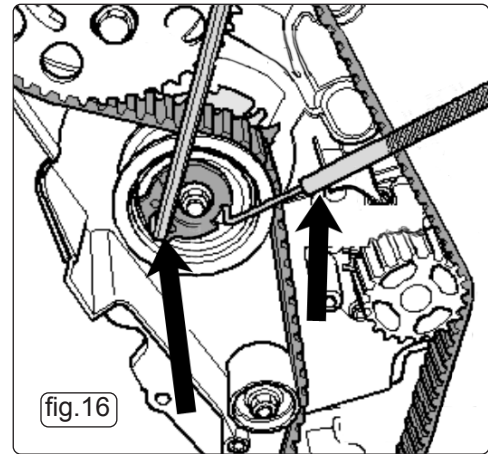

VSE5951-V2-07 Tensioner Locking Tool  
VSE5951-V2-06 Tensioner Adjuster

- 5.9.1. On a number of models (from 2004) a larger engine mounting was introduced. With these new larger mountings the revised routing of the timing belt has resulted in removal and fitting of the belt without the need to remove or detach the engine mounting. At the same time a new belt tensioner was introduced together with new tensioner tools which are required to gain access to the tensioner in the limited space available.

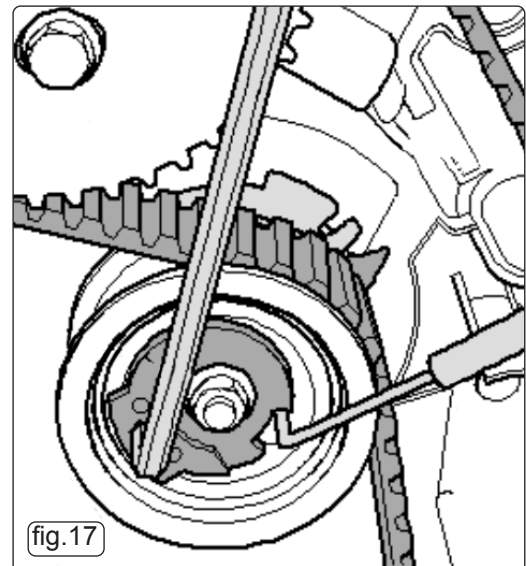

- 5.9.2. VSE5951-06 Tensioner Adjuster locates into the hexagon provided on the tensioner in order to turn the tensioner for release or to apply belt tension. VSE5951-07 Tensioner Locking Tool 'locks' the tensioner in a position off the timing belt allowing the belt to be removed.

## 5.10. Timing Belt Installation, Common Rail engines.

5.10.1. Prior to fitting a new belt on common rail engines, the 3 bolts on the camshaft sprocket and the 3 bolts on the HP pump are loosened, allowing the sprocket to turn but not tilt.

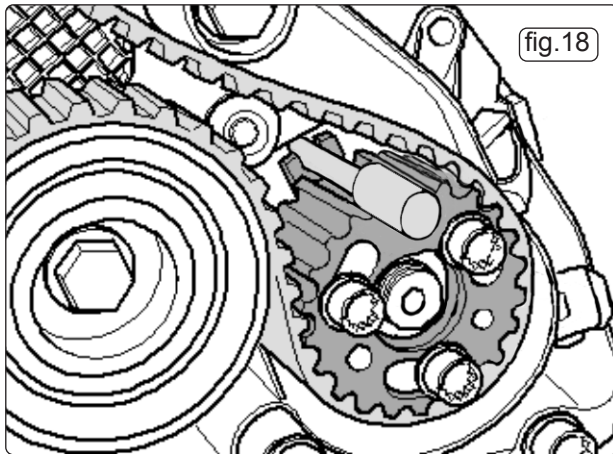

5.10.2. The crankshaft must be 'locked' using the correct Locking Tool and VSE5951-07 Tensioner Locking Tool should be inserted in the belt tensioner, and Locking Pins VSE5951-01 inserted through the camshaft sprocket and HP pump sprocket (fig. 18).

**NOTE:** The camshaft sprocket and HP pump sprocket should be turned in their elongated holes **clockwise** to the "stop".

5.10.3. The new belt is fitted in order - crankshaft gear, tensioner, camshaft sprocket, coolant pump sprocket, HP pump sprocket and finally, idler roller.

The tensioner is released and VSE5951-07 Locking Tool pulled out. A suitable Sprocket Holding Tool is attached to the camshaft sprocket and pressure applied in an **anticlockwise** direction to maintain tension on the sprocket/belt whilst tightening the camshaft sprocket bolts and HP pump sprocket bolts. **NOTE:** Always fit new bolts.

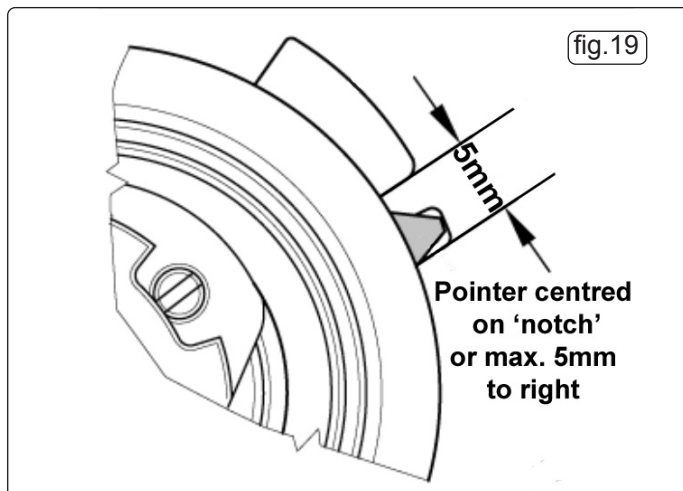

5.10.4. The belt tensioner is turned **clockwise** using VSE5951-06 Adjuster until the pointer aligns with the "notch" on the back plate. Ensure the retaining nut does not turn, and whilst maintaining this position, tighten the tensioner nut.

**IMPORTANT:** The tensioner pointer position must be maintained whilst tightening the tensioner nut. The tensioner pointer may be allowed to move **clockwise** a **maximum of 5mm.** to the right of the "notch". This will correct after the engine has run for a short time (fig.19).

5.10.5. Remove **all** timing tools and turn the engine over twice, by hand, returning to TDC No.1 cylinder. Fit the crankshaft and camshaft locking tools to check engine timing is correct, and also check that the tensioner pointer is centred (or a maximum of 5mm. to the right) of the "notch" on the back plate. If there is any difficulty fitting the timing tools – refer to "Adjusting Timing" sections

## 5.11. Adjusting Timing - 8v. single camshaft Pumpe Düse engines.

5.11.1. Once the correct Crankshaft Locking Tool has been fitted to the crankshaft gear and has 'locked' the engine at TDC No.1 cylinder, the Camshaft Locking Pin is inserted through the camshaft sprocket.

If the Locking Pin cannot be inserted easily to 'lock' the camshaft – then timing adjustment will be necessary. Adjust the timing as follows:

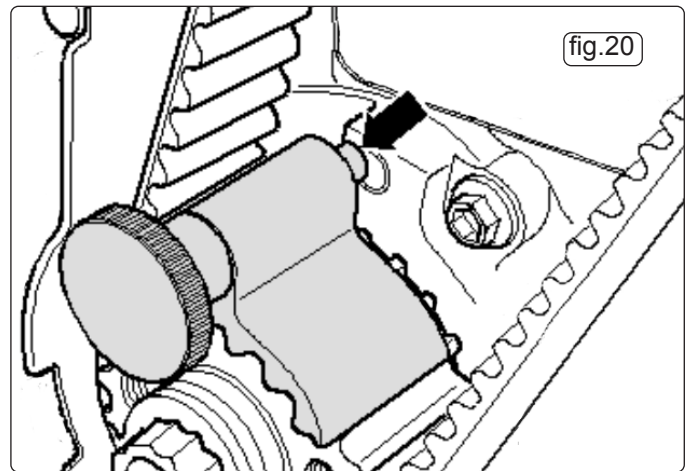

5.11.2. The Crankshaft Locking Tool is pulled forward on the crankshaft gear in order that it is no longer engaged in the hole in the oil seal housing, and therefore not 'locking' the crankshaft.

The camshaft can then be turned slowly until the Camshaft Locking Pin can be inserted. The 3 camshaft bolts are loosened, allowing the sprocket to turn in the elongated holes in the sprocket.

5.11.3. The crankshaft is turned slowly in an **anticlockwise** direction until the lug in the back of the Crankshaft Locking Tool slightly passes the hole in the oil seal housing and then the crankshaft is turned **clockwise** until the Locking Tool can be inserted into the hole to 'lock' the crankshaft.

5.11.4. Using a suitable Holding Tool counter hold the camshaft sprocket and tighten the camshaft sprocket bolts. **NOTE:** Always fit new sprocket bolts.

5.11.5. Once completed, **all** the tools are removed and the engine turned over twice, by hand, returning to TDC No.1 cylinder, and the timing tools installed to check the engine timing position.

## 5.12. Adjusting Timing - 16v. twin camshaft Pumpe Düse engines.

5.12.1. Once the correct Crankshaft Locking Tool has been fitted to the crankshaft gear and has 'locked' the engine at TDC No.1 cylinder, the Camshaft Locking Pins are inserted through the camshaft sprockets.



5.12.2. (1) If the Locking Pin cannot be inserted easily to 'lock' the right hand camshaft - then timing adjustment will be necessary, as follows:  
The 3 bolts of the right hand sprocket are loosened, allowing the sprocket to turn in the elongated holes in the sprocket. Use a spanner on the centre bolt and turn the sprocket until the Locking Pin can be inserted. Using a suitable Holding Tool counter hold the camshaft sprocket and tighten the sprocket bolts.

**NOTE:** Always fit new sprocket bolts.

Once completed, **all** the tools are removed and the engine turned over twice, by hand, returning to TDC No.1 cylinder, and the timing tools installed to check the engine timing position.

**NOTE:** also check the tensioner pointer is aligned with "notch"

5.12.3. (2) If the camshaft sprocket Locking Pins can be inserted **BUT** the Crankshaft Locking Tool cannot be correctly fitted - adjust the timing as follows:  
Insert the Camshaft Locking Pins to 'lock' both camshafts and release the 6 bolts allowing the sprockets to turn in the elongated holes.

Turn the crankshaft in normal direction of engine rotation to fit the Crankshaft Locking Tool and using a suitable Holding Tool counter hold the camshaft sprockets and tighten the sprocket bolts.

**NOTE:** Always fit new bolts.

Once completed, **all** the tools are removed and the engine turned over twice by hand, returning to TDC No.1 cylinder, and the timing tools installed to check the engine timing position.

**NOTE:** also check the tensioner pointer is aligned with "notch".

### 5.13. Adjusting Timing – 16v. 1.2, 1.6, 2.0 Common Rail engines.

5.13.1. Once the correct Crankshaft Locking Tool has been fitted to the crankshaft gear and has 'locked' the engine at TDC No.1 cylinder, the Camshaft Locking Pin is inserted through the camshaft sprocket. The tensioner pointer will be centred in the "notch" in the baseplate. If the Locking Pin cannot be inserted easily to 'lock' the camshaft – then timing adjustment will be necessary.

5.13.2. Adjust the timing as follows:

**NOTE:** Once the new belt has been fitted and the timing is being checked, the HP pump Locking Pin may not be able to be inserted into the hole to 'lock' the pump, a slight misalignment may occur. However this slight misalignment does not influence the engine performance.

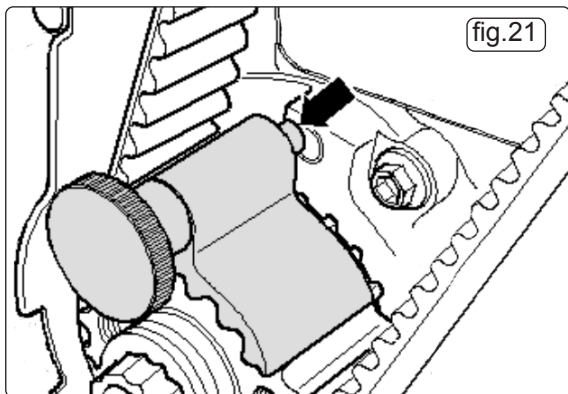

5.13.3. The Crankshaft Locking Tool is pulled forward on the crankshaft gear in order that it is no longer engaged in the hole in the oil seal housing, and therefore not 'locking' the crankshaft (fig.21).

5.13.4. The crankshaft is then turned slowly in the opposite direction of engine rotation until the lug of the Crankshaft Locking Tool slightly passes the hole in the oil seal housing. The crankshaft is then turned in the normal direction of engine rotation until the Camshaft Locking Pin can be inserted.

5.13.5. The 3 camshaft bolts are loosened, allowing the sprocket to turn within the elongated holes. The lug of the Crankshaft Locking tool will be positioned to the right or left of the hole in the oil seal housing

5.13.6. **If to the right:** slowly turn the crankshaft back (opposite direction of engine rotation) until it passes the hole and then turn crankshaft in the normal direction of engine rotation and insert the lug into the hole (and 'lock' the crankshaft). Using a suitable Holding Tool counter hold the camshaft sprocket and tighten the sprocket bolts.

5.13.7. **If to the left:** slowly turn the crankshaft in direction of normal engine rotation and insert the lug into the hole (and 'lock' the crankshaft). Using a suitable Holding Tool counter hold the camshaft sprocket and tighten the sprocket bolts.

**NOTE:** Always fit new sprocket bolts.

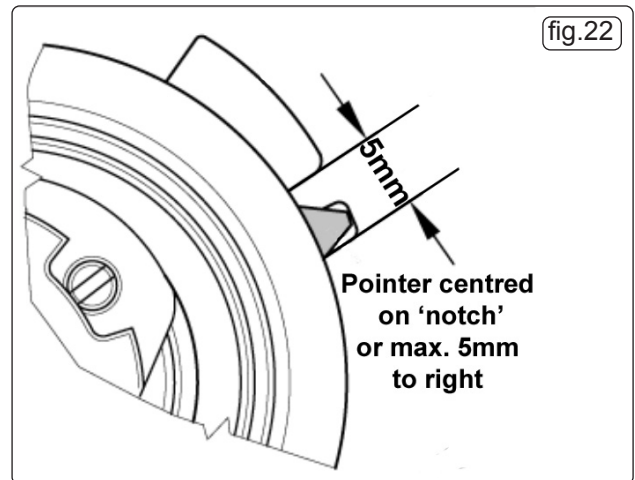

5.13.8. Once completed, **all** the timing tools are removed and the engine turned over twice, by hand, returning to TDC No.1 cylinder, and the timing tools installed to again check the engine timing position. Check that the belt tensioner pointer is centred (or a maximum of 5mm. to the right) in the "notch" in the back plate (fig.22).



#### ENVIRONMENT PROTECTION

Recycle unwanted materials instead of disposing of them as waste. All tools, accessories and packaging should be sorted, taken to a recycling centre and disposed of in a manner which is compatible with the environment. When the product becomes completely unserviceable and requires disposal, drain any fluids (if applicable) into approved containers and dispose of the product and fluids according to local regulations.



**Note:** It is our policy to continually improve products and as such we reserve the right to alter data, specifications and component parts without prior notice. Please note that other versions of this product are available. If you require documentation for alternative versions, please email or call our technical team on [technical@sealey.co.uk](mailto:technical@sealey.co.uk) or 01284 757505.

**Important:** No Liability is accepted for incorrect use of this product.

**Warranty:** Guarantee is 12 months from purchase date, proof of which is required for any claim.

Sealey Group, Kempson Way, Suffolk Business Park, Bury St Edmunds, Suffolk. IP32 7AR



01284 757500



[sales@sealey.co.uk](mailto:sales@sealey.co.uk)



[www.sealey.co.uk](http://www.sealey.co.uk)